



Photometric Test Report



EclDysplay CRMXFC

PROFILE LENS 50°

40 RGB+WW LED Spotlight with Wireless CRMX and wired control, without lens

CONTENTS

Table of contents	2
Testing process	3
Color temperature Full On	4
Color temperature Red	9
Color temperature Green	12
Color temperature Blue	15
Color temperature White	18
Color temperature 2800K	23
Color temperature 3200K	28
Color temperature 4000K	33
Color temperature 5600K	38
Color temperature 6000K	43

TESTING PROCESS

Prolights has its own optical testing laboratory in order to provide accurate photometric reports for its lighting products. The testing laboratory contains certain variety of precise lighting measurement systems that ensure an optimal reading of all the characteristic parameters of the lighting devices. All measurements are made at a controlled room temperature of 20°C without any external light sources. This photometric report is obtained through the data measured by a high precision measurement system and analyzed by a dedicate software.

Prolights measurement instrument

Prolights measurement instrument is a complete measurement system for any light source. It's equipped with two-axis goniometer, that enables to measure the full 3D distribution field of the light source. This instrument measures the light intensity, the beam angle and the most significative colors parameters, like color temperature, spectral distribution, CRI, CQS, TM-30 with a very high accuracy rate.

Please Note: All measurements are made with light source at operating temperature. Before starting the measurement, the instrument analyzes the process of the light source during the heating phase. The measuring process of all the parameters begins only when the light emission is stable, that is with a variation of less than 0.5% in a 15 minutes time frame.

Prolights measurement software

The software provides user friendly interface for the operator who does the measurements, and it also analyzes and processes all the collected data by the instrument. With this software it is possible to see the measured data in real-time and it is possible to examine all the measured data and graphics afterwards as well. All information is collected in a specific Prolights template, and the software creates also IES and LDT files, which are widely used to transfer the photometric data, and to develop lighting system.

Additionally, the fixtures are rechecked using various hand-held instruments like Sekonic C-700 and Gossen Mavospec Base, this is done to ensure, that the data in the photometric report are as accurate as possible.



Total lumen output:

316 lm

Peak candela output:

622 cd

Light quality:

CRI: 91,4

Color temperature:

5994 K

PRODUCT NAME:

ECLDISPLAY FC

MEASURAMENT CONDITIONS:

Beam angle:

Profile 50°

Target:

Full On

Operator:

Salvatore Giglio

Date and time:

07/02/2024 09:31:38

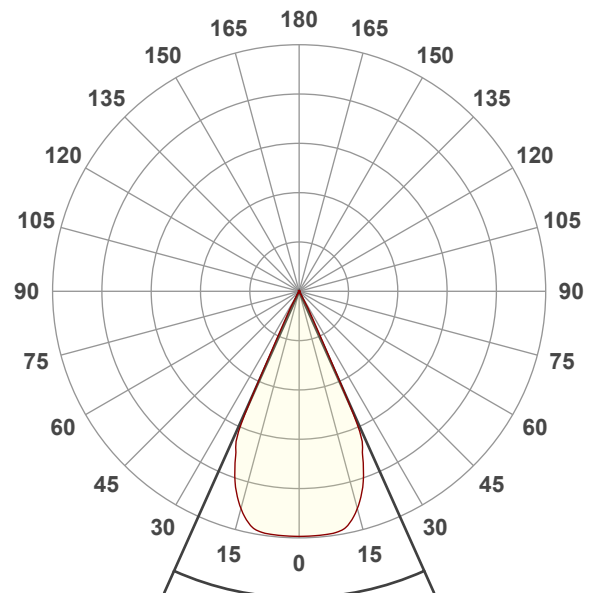

Beam angle 50%: 48,2°

Field angle 10%: 53,7°

Cut off angle 2.5%: 56,8°

Spectra

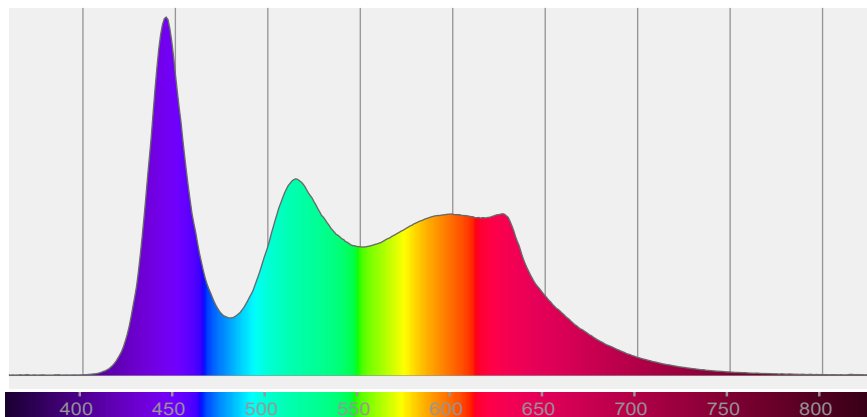

COLOR DETAILS

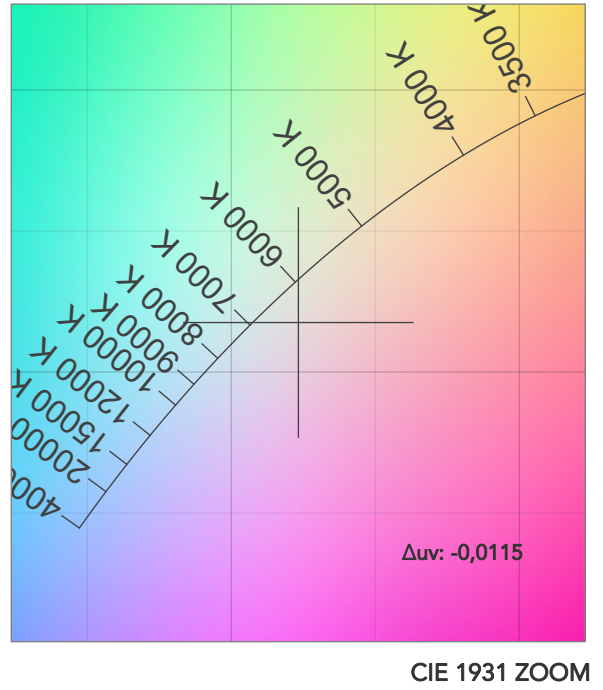
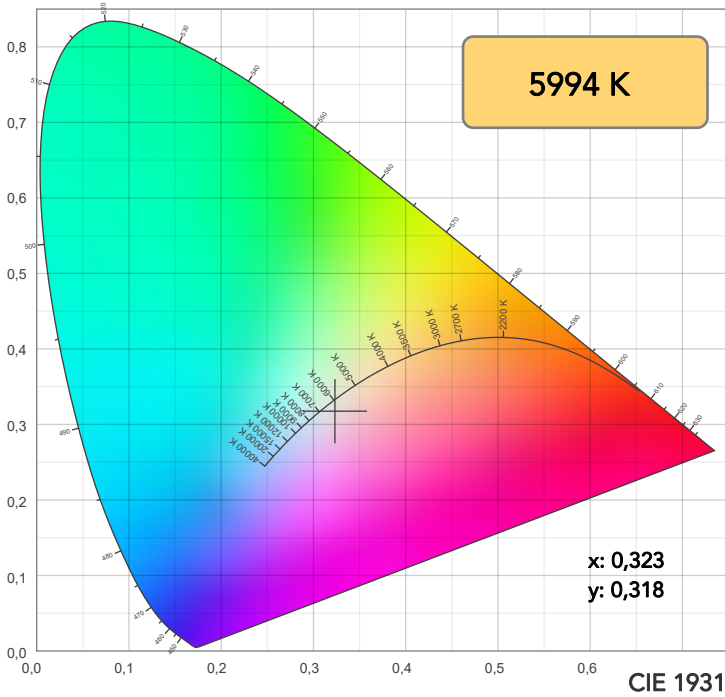

TM30: 87,9

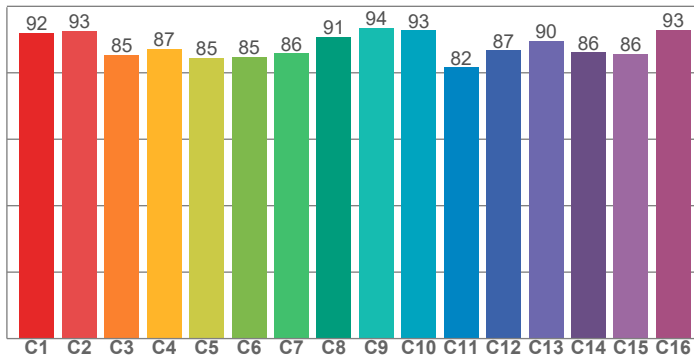

CRI: 91,4 (R1-R8)

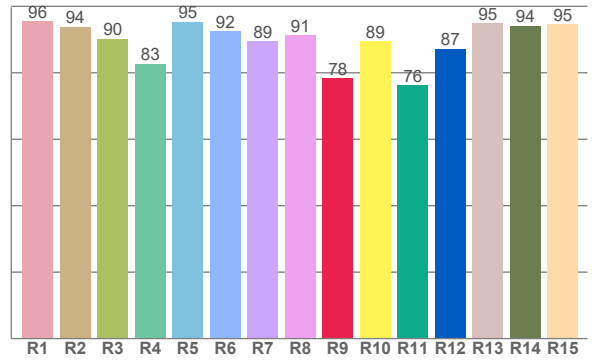

CQS: 90,4

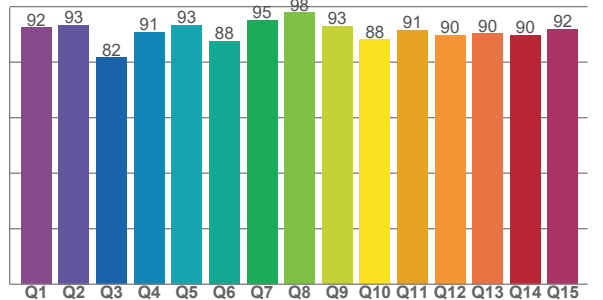

CRI R values, only R1-R8 are used to calculate final CRI value

R1	R2	R3	R4	R5	R6	R7	R8	R9	R10	R11	R12	R13	R14	R15
95,6	93,9	90,2	82,7	95,4	92,5	89,5	91,2	78,3	89,4	76,3	87,2	94,9	94,1	94,5

TM30 C values, 16 binned values out of total of 99 C values

C1	C2	C3	C4	C5	C6	C7	C8	C9	C10	C11	C12	C13	C14	C15	C16
92,0	92,6	85,4	87,2	84,6	84,8	85,9	90,8	93,6	92,8	81,6	86,8	89,6	86,2	85,7	92,9

CQS Q values

Q1	Q2	Q3	Q4	Q5	Q6	Q7	Q8	Q9	Q10	Q11	Q12	Q13	Q14	Q15
92,5	93,4	81,7	90,8	93,3	87,6	95,2	97,8	92,9	88,1	91,5	89,8	90,4	89,7	91,8

COLOR PARAMETERS

Color temperature	Color rendering index	Red component	Color fidelity	Color gamut	Color quality scale	Television lighting index	Color coordinate cie 1931	Color coordinate cie 1931	Color deviation from black body
CCT	CRI	CRI R9	TM30 Rf	TM30 Rg	CQS	TLCI	x	y	Δuv
5994 K	91,4	78,3	87,9	107,4	90,4	82	0,323	0,318	-0,0115

TM30 DETAILS

Rf 87,9
Fidelity index Rf

Rg 107,4
Gammut index

Hue Bin	R _f	Graphic shifts (%)	
		Chroma	Hue
1	92	-3%	-2%
2	93	-2%	4%
3	85	1%	8%
4	87	3%	7%
5	85	7%	6%
6	85	10%	4%
7	86	10%	0%
8	91	4%	-3%
9	94	0%	-3%
10	93	-2%	2%
11	82	0%	11%
12	87	4%	8%
13	90	8%	4%
14	86	8%	3%
15	86	10%	-8%
16	93	3%	-3%

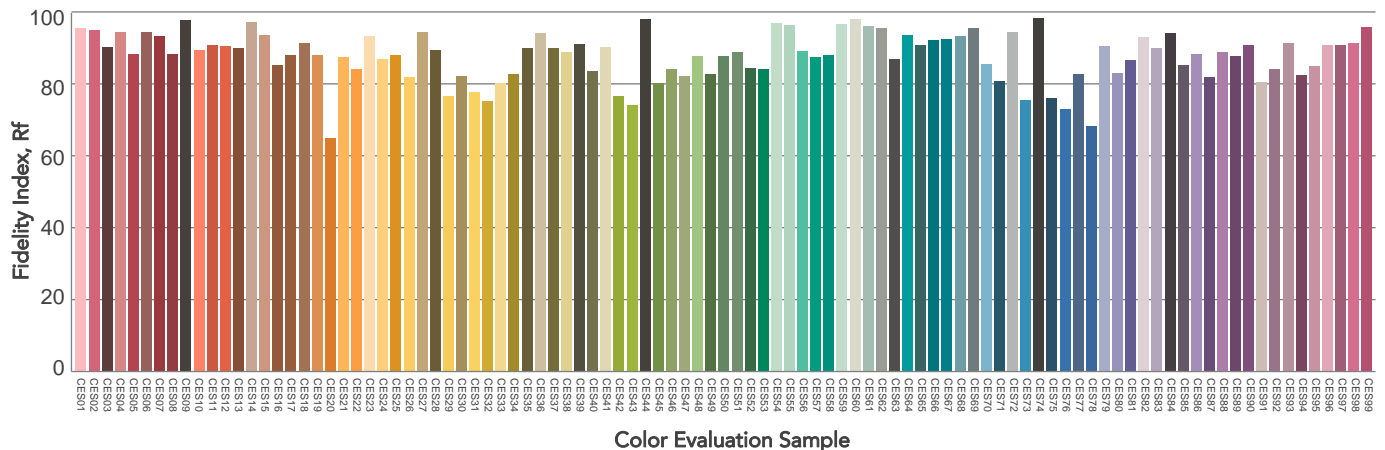
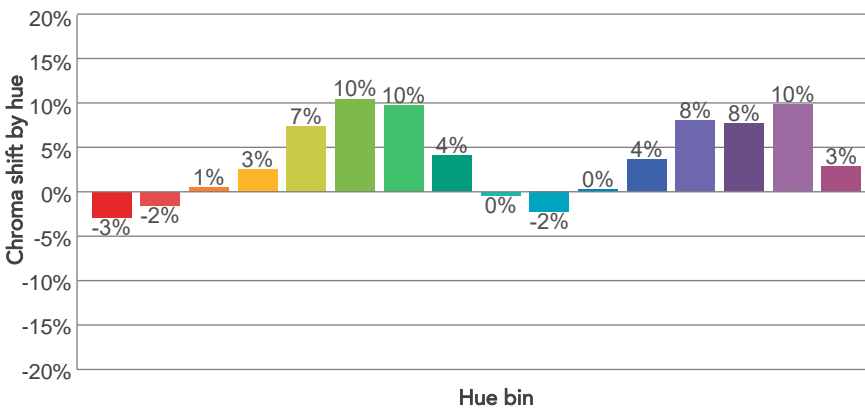
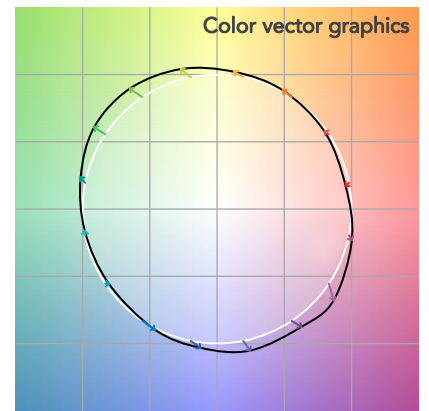
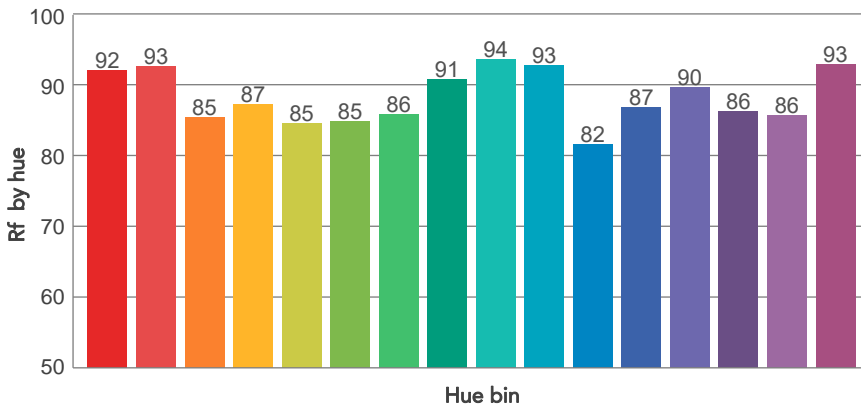
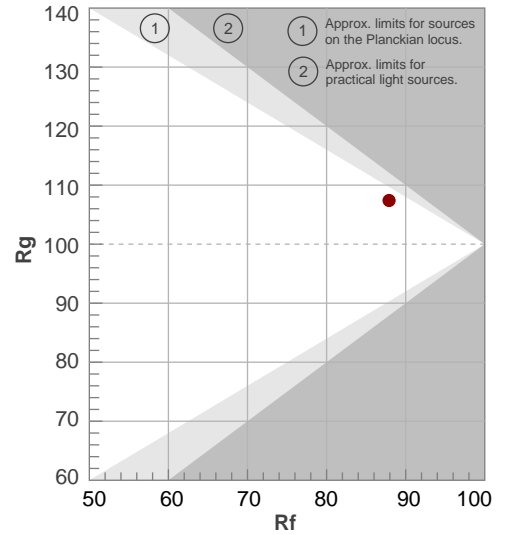

BEAM DETAILS



Beam angle 50%	Field angle 10%	Cut off angle 2,5%	Intensity ratio in 120° cone	Intensity ratio in 90° cone
48,2°	53,7°	56,8°	99,0%	98,6%

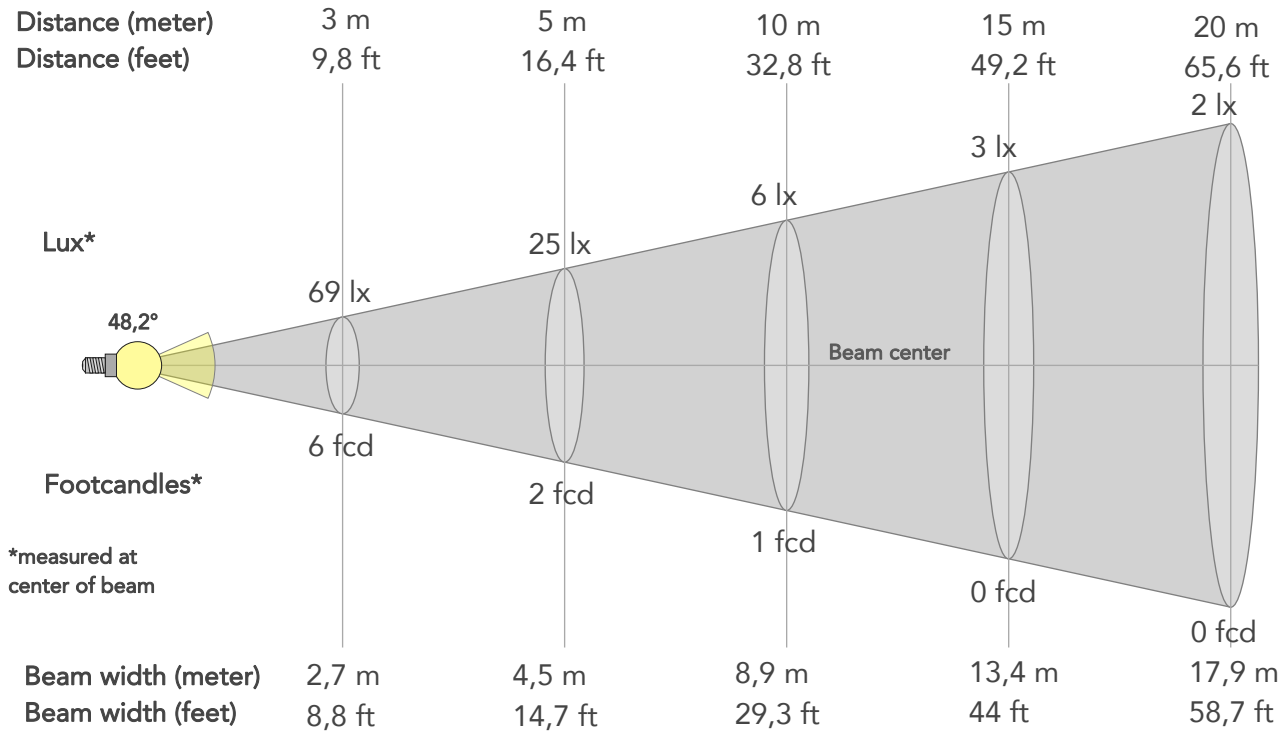

BEAM INTENSITIES AND WIDTHS

Distance	1m	2m	3m	4m	5m	7,5m	10m	15m	20m	25m	30m	40m	50m
Distance	3,3ft	6,6ft	9,8ft	13,1ft	16,4ft	24,6ft	32,8ft	49,2ft	65,6ft	82ft	98,4ft	131,2ft	164ft
Lux	622lx	156lx	69lx	39lx	25lx	11lx	6lx	3lx	2lx	1lx	1lx	0lx	0lx
Footcand.	58fcd	14fcd	6fcd	4fcd	2fcd	1fcd	1fcd	0fcd	0fcd	0fcd	0fcd	0fcd	0fcd
Beam wid.	0,9m	1,8m	2,7m	3,6m	4,5m	6,7m	8,9m	13,4m	17,9m	22,4m	26,8m	35,8m	44,7m
Beam wid.	3ft	5,9ft	8,8ft	11,7ft	14,7ft	22ft	29,3ft	44ft	58,7ft	73,4ft	88ft	117,4ft	146,7ft

LINEAR DISTRIBUTION DIAGRAM

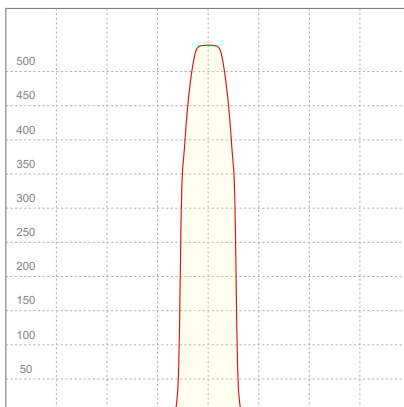

ELECTRICAL SPECIFICATIONS

Input voltage	Input current	Input power	Power FC	Efficiency
225V	0,288A	29,9W	0,46	11lm/W

ISO DIAGRAMS

ISO CANDELA DIAGRAM

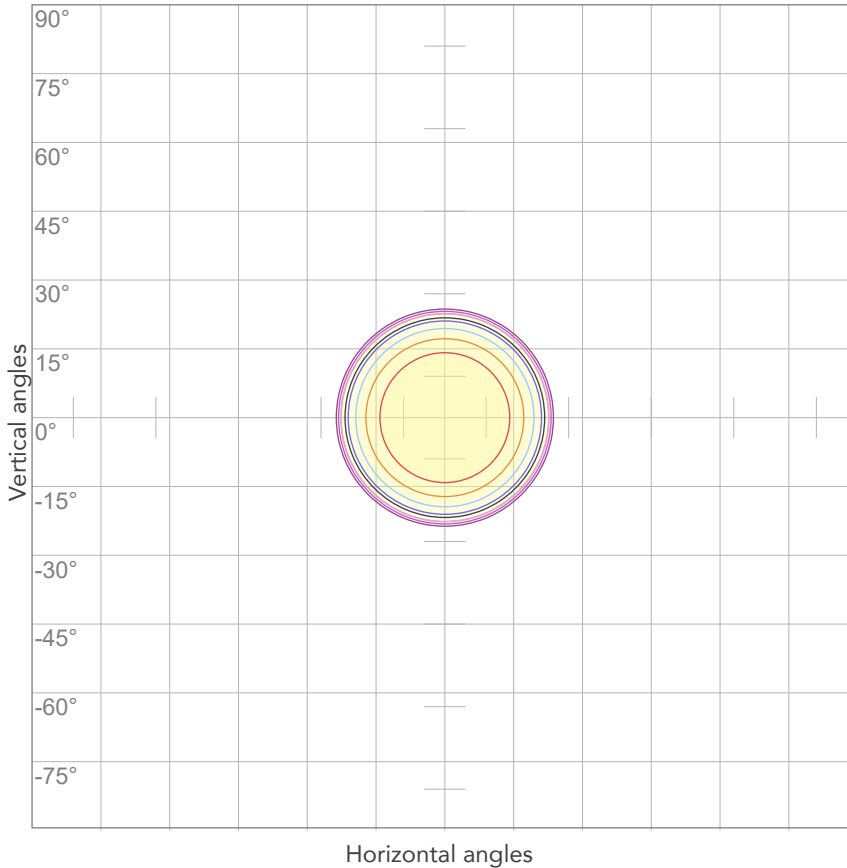

10%	62 cd
20%	124 cd
30%	187 cd
40%	249 cd
50%	311 cd
60%	373 cd
70%	436 cd
80%	498 cd

Conditions:

Number of c-planes: 2
Candela at center: 622 cd

ISO LUX DIAGRAM

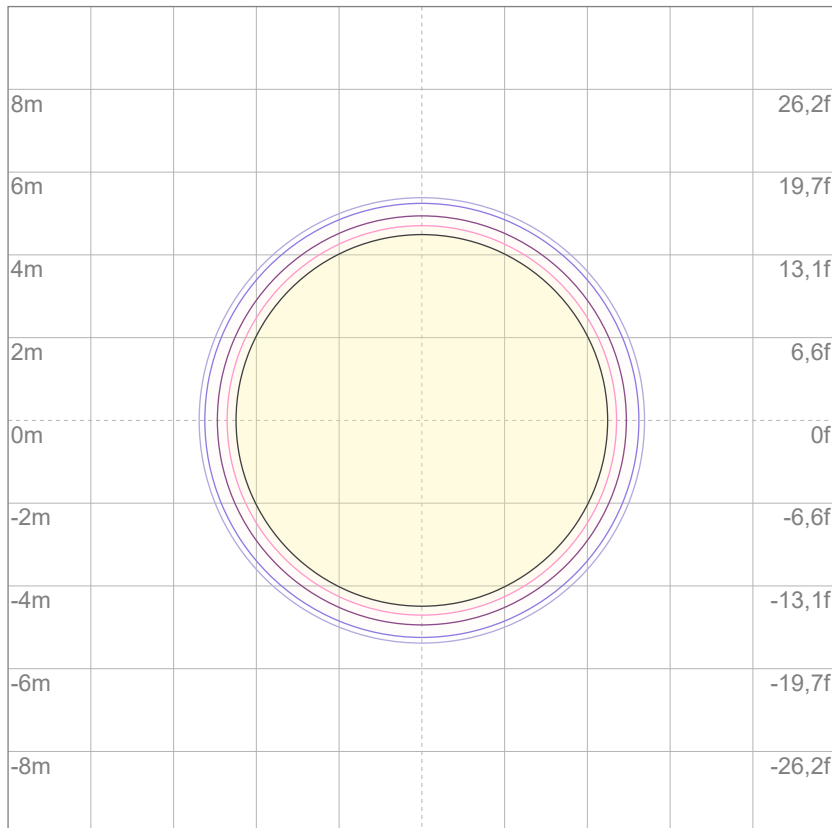

3%	0,187 lx
5%	0,311 lx
10%	0,622 lx
30%	1,87 lx
50%	3,11 lx

Conditions:

Number of c-planes: 2
Lux at center: 6,22 lx

Lux distribution on a surface when lamp is mounted at 10 meters from the surface.

Mounting height: 10 meters (33 feet)



Total lumen output:

94,1 lm

Peak candela output:

183 cd

PRODUCT NAME:

ECLDISPLAY FC

MEASURAMENT CONDITIONS:

Beam angle:

Profile 50°

Target:

Red

Operator:

Salvatore Giglio

Date and time:

07/02/2024 09:33:18

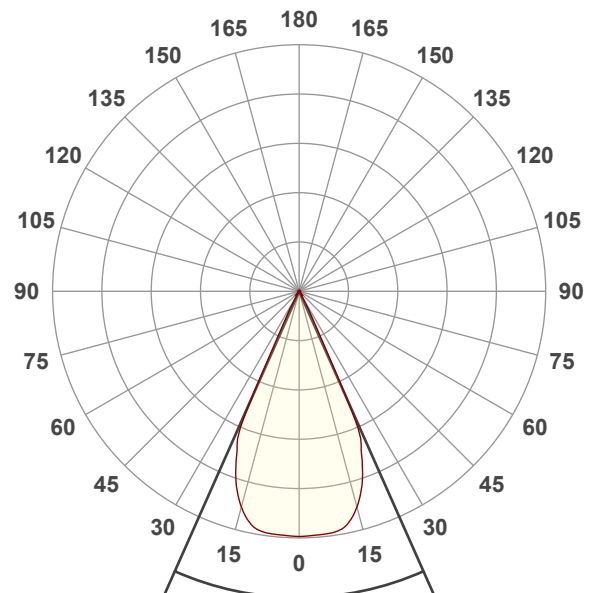

Beam angle 50%: 47,9°

Field angle 10%: 53,7°

Cut off angle 2.5%: 57°

Spectra

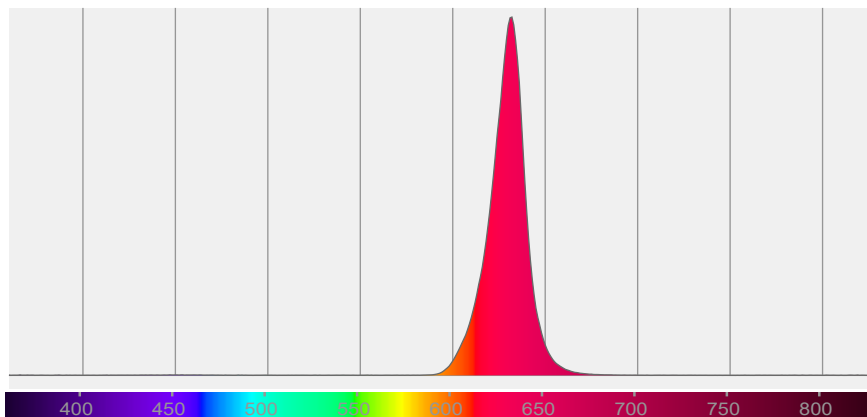

BEAM DETAILS



Beam angle 50%	Field angle 10%	Cut off angle 2,5%	Intensity ratio in 120° cone	Intensity ratio in 90° cone
47,9°	53,7°	57°	97,3%	96,4%

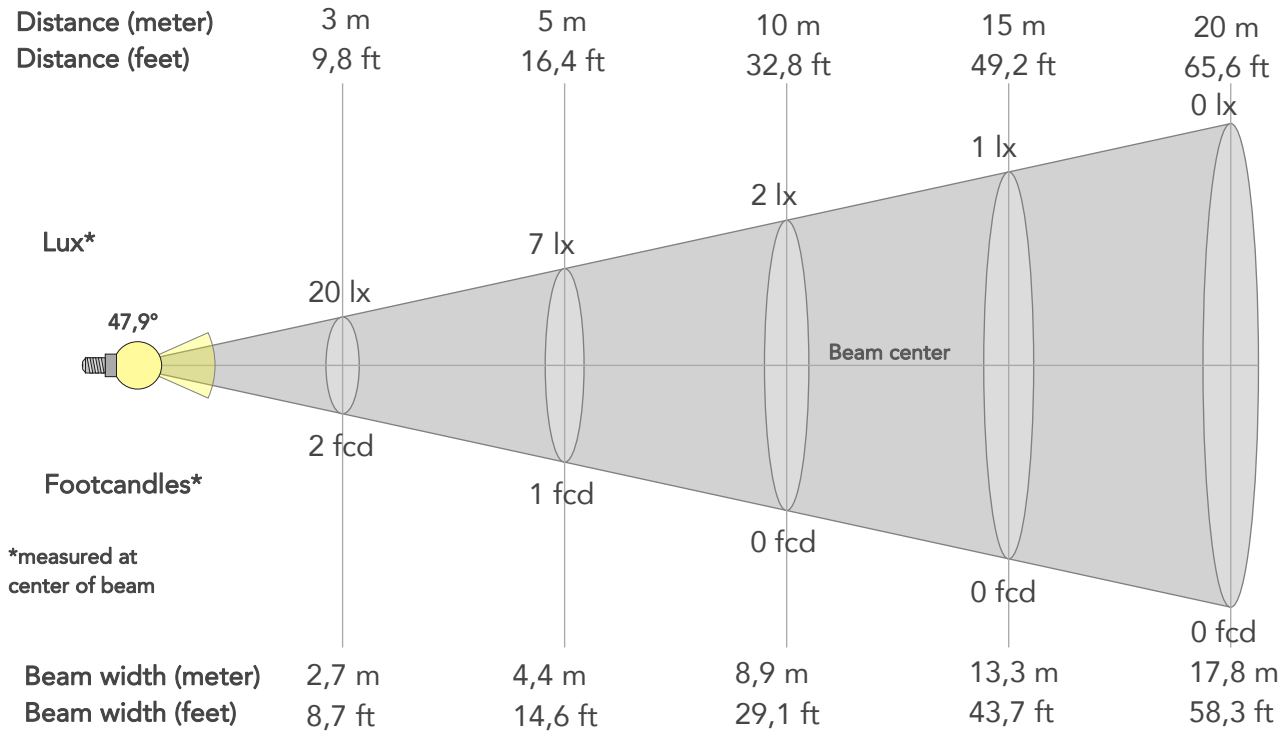

BEAM INTENSITIES AND WIDTHS

Distance	1m	2m	3m	4m	5m	7,5m	10m	15m	20m	25m	30m	40m	50m
Distance	3,3ft	6,6ft	9,8ft	13,1ft	16,4ft	24,6ft	32,8ft	49,2ft	65,6ft	82ft	98,4ft	131,2ft	164ft
Lux	183lx	46lx	20lx	11lx	7lx	3lx	2lx	1lx	0lx	0lx	0lx	0lx	0lx
Footcand.	17fcd	4fcd	2fcd	1fcd	1fcd	0fcd	0fcd	0fcd	0fcd	0fcd	0fcd	0fcd	0fcd
Beam wid.	0,9m	1,8m	2,7m	3,6m	4,4m	6,7m	8,9m	13,3m	17,8m	22,2m	26,6m	35,5m	44,4m
Beam wid.	2,9ft	5,9ft	8,7ft	11,6ft	14,6ft	21,8ft	29,1ft	43,7ft	58,3ft	72,8ft	87,4ft	116,5ft	145,7ft

LINEAR DISTRIBUTION DIAGRAM

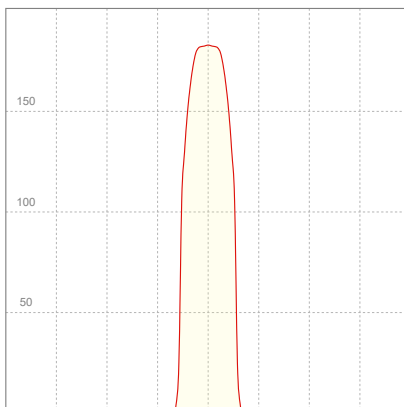

ELECTRICAL SPECIFICATIONS

Input voltage	Input current	Input power	Power FC	Efficiency
225V	0,145A	13,3W	0,41	7lm/W

ISO DIAGRAMS

ISO CANDELA DIAGRAM

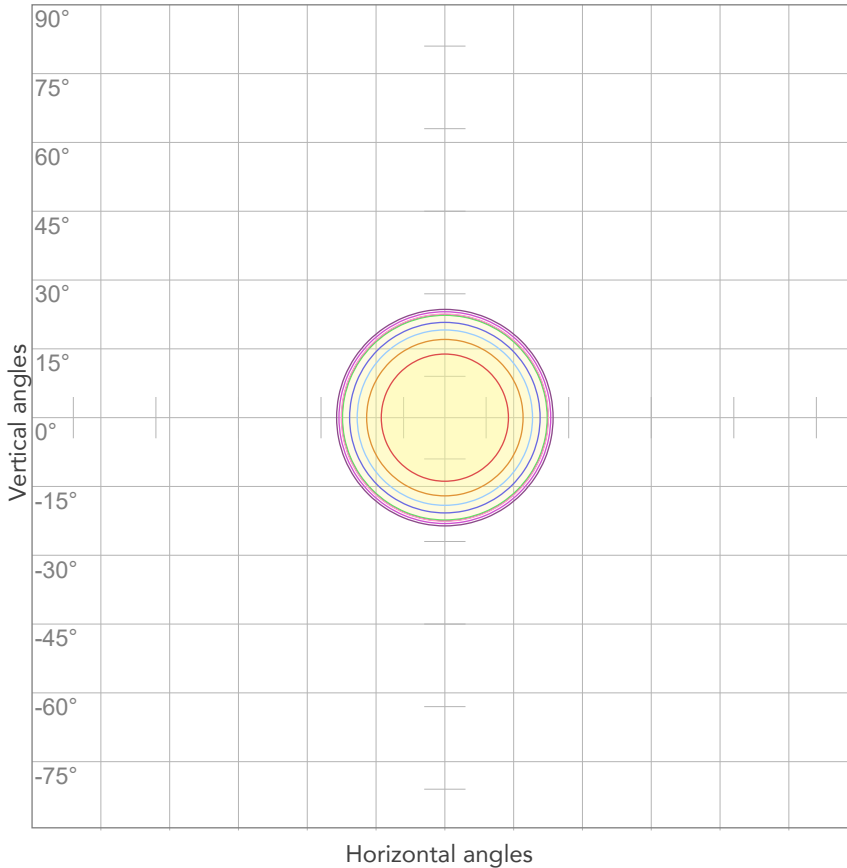

10%	18 cd
20%	37 cd
30%	55 cd
40%	73 cd
50%	91 cd
60%	110 cd
70%	128 cd
80%	146 cd

Conditions:

Number of c-planes: 2

Candela at center: 183 cd

ISO LUX DIAGRAM

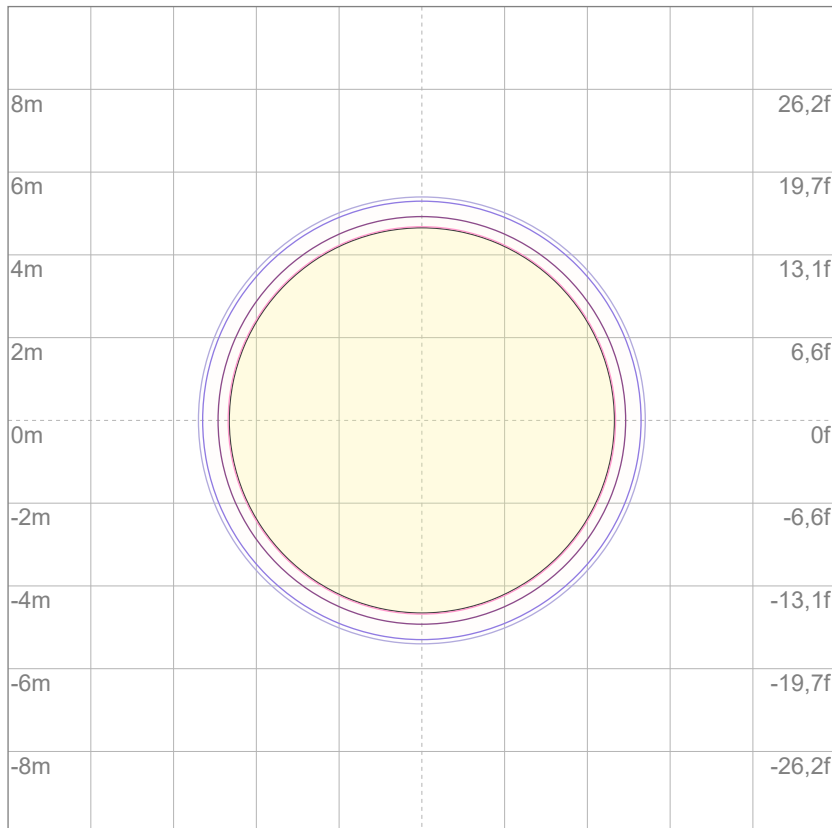

3%	54,9m lx
5%	91,4m lx
10%	0,183 lx
30%	0,549 lx
50%	0,914 lx

Conditions:

Number of c-planes: 2

Lux at center: 1,83 lx

Lux distribution on a surface when lamp is mounted at 10 meters from the surface.

Mounting height: 10 meters (33 feet)



Total lumen output:

171 lm

Peak candela output:

327 cd

PRODUCT NAME:

ECLDISPLAY FC

MEASURAMENT CONDITIONS:

Beam angle:

Profile 50°

Target:

Green

Operator:

Salvatore Giglio

Date and time:

07/02/2024 09:34:49

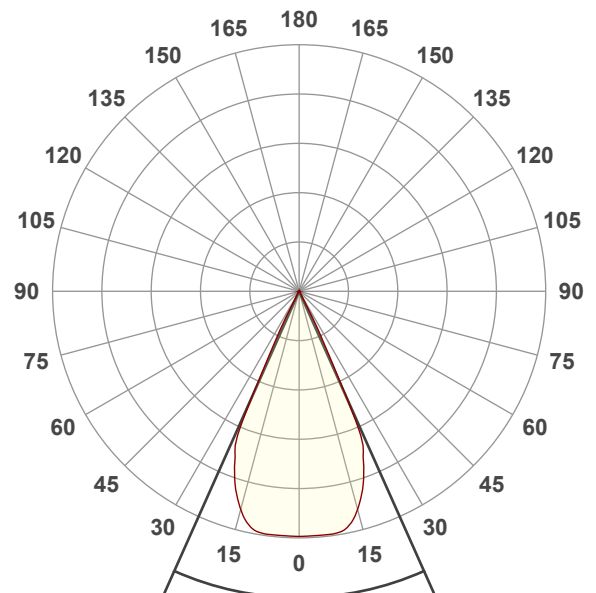

Beam angle 50%: 48,1°

Field angle 10%: 54,6°

Cut off angle 2.5%: 56,6°

Spectra

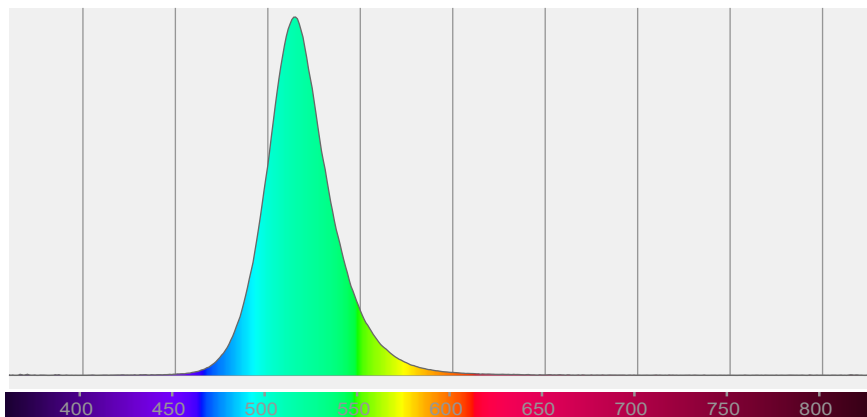

BEAM DETAILS



Beam angle 50%	Field angle 10%	Cut off angle 2,5%	Intensity ratio in 120° cone	Intensity ratio in 90° cone
48,1°	54,6°	56,6°	97,8%	97,2%

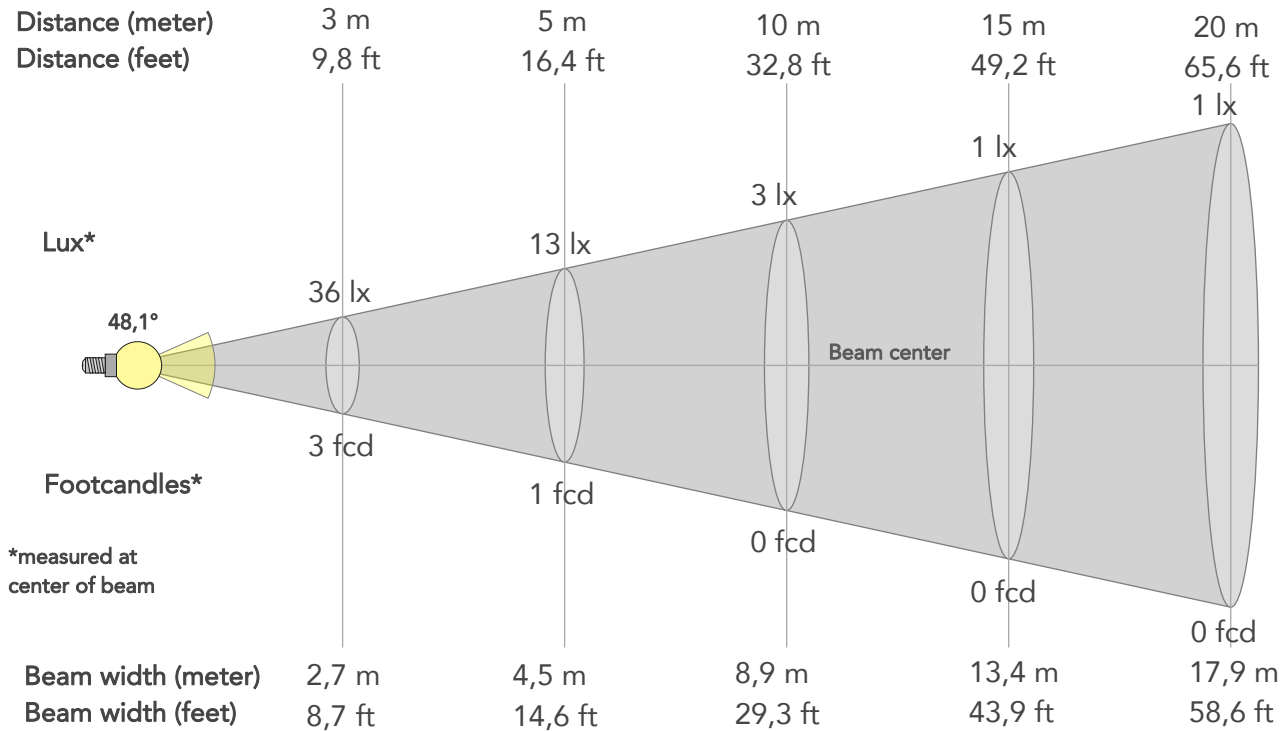

BEAM INTENSITIES AND WIDTHS

Distance	1m	2m	3m	4m	5m	7,5m	10m	15m	20m	25m	30m	40m	50m
Distance	3,3ft	6,6ft	9,8ft	13,1ft	16,4ft	24,6ft	32,8ft	49,2ft	65,6ft	82ft	98,4ft	131,2ft	164ft
Lux	327lx	82lx	36lx	20lx	13lx	6lx	3lx	1lx	1lx	1lx	0lx	0lx	0lx
Footcand.	30fcd	8fcd	3fcd	2fcd	1fcd	1fcd	0fcd	0fcd	0fcd	0fcd	0fcd	0fcd	0fcd
Beam wid.	0,9m	1,8m	2,7m	3,6m	4,5m	6,7m	8,9m	13,4m	17,9m	22,3m	26,8m	35,7m	44,6m
Beam wid.	2,9ft	5,9ft	8,7ft	11,7ft	14,6ft	22ft	29,3ft	43,9ft	58,6ft	73,2ft	87,8ft	117,1ft	146,4ft

LINEAR DISTRIBUTION DIAGRAM

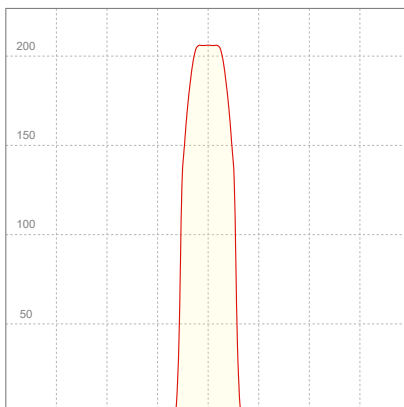

ELECTRICAL SPECIFICATIONS

Input voltage	Input current	Input power	Power FC	Efficiency
225V	0,164A	14,8W	0,4	12lm/W

ISO DIAGRAMS

ISO CANDELA DIAGRAM

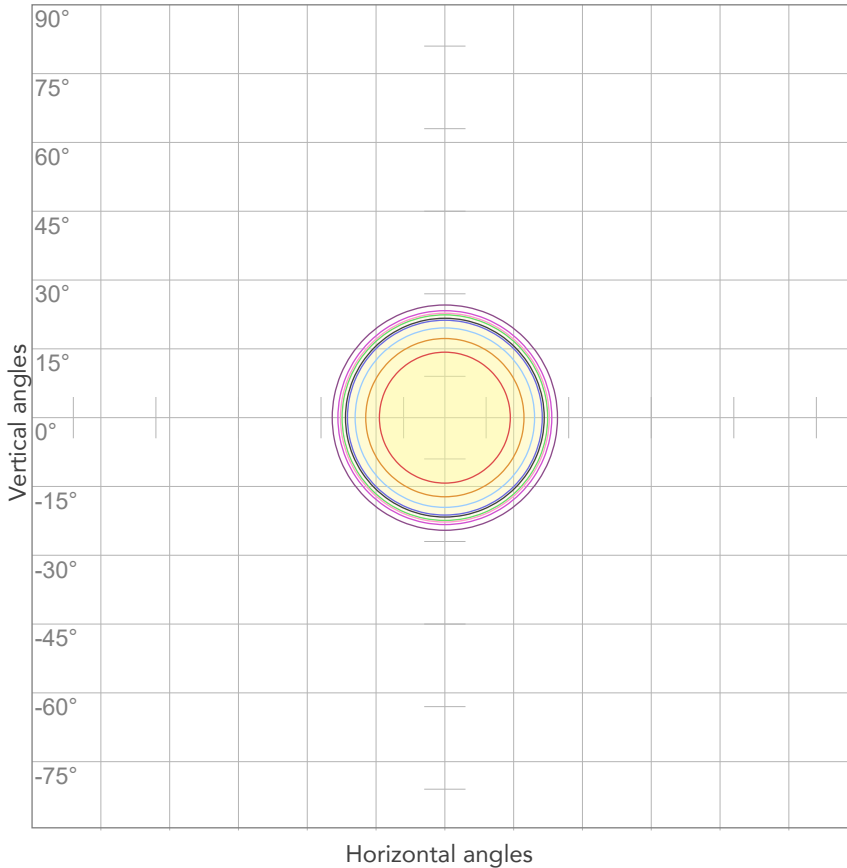

10%	33 cd
20%	65 cd
30%	98 cd
40%	131 cd
50%	164 cd
60%	196 cd
70%	229 cd
80%	262 cd

Conditions:

Number of c-planes: 2

Candela at center: 327 cd

ISO LUX DIAGRAM

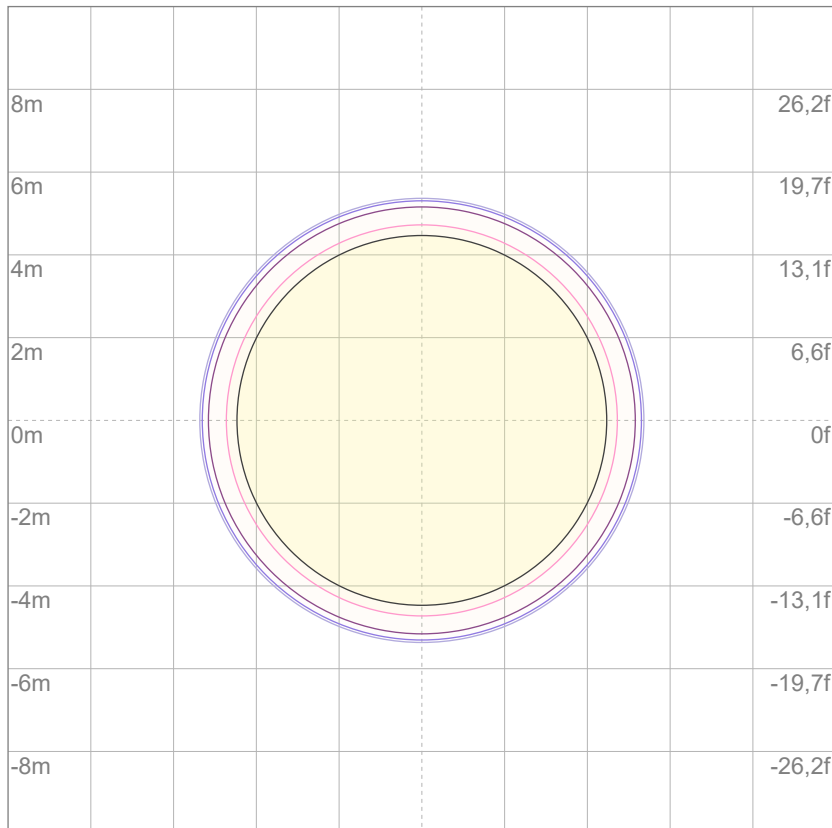

Mounting height: 10 meters (33 feet)

3%	98,2m lx
5%	0,164 lx
10%	0,327 lx
30%	0,982 lx
50%	1,64 lx

Conditions:

Number of c-planes: 2

Lux at center: 3,27 lx

Lux distribution on a surface when lamp is mounted at 10 meters from the surface.



Total lumen output:

36,6 lm

Peak candela output:

64,9 cd

PRODUCT NAME:

ECLDISPLAY FC

MEASURAMENT CONDITIONS:

Beam angle:

Profile 50°

Target:

Blue

Operator:

Salvatore Giglio

Date and time:

07/02/2024 09:36:23

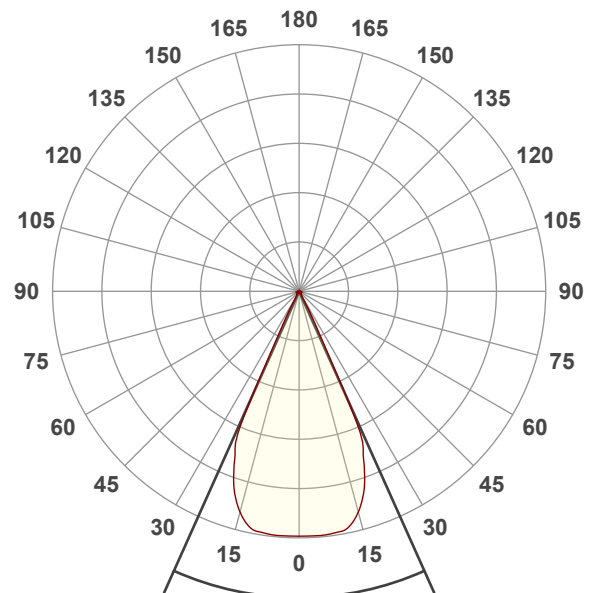

Beam angle 50%: 48,3°

Field angle 10%: 54,1°

Cut off angle 2.5%: 56,9°

Spectra

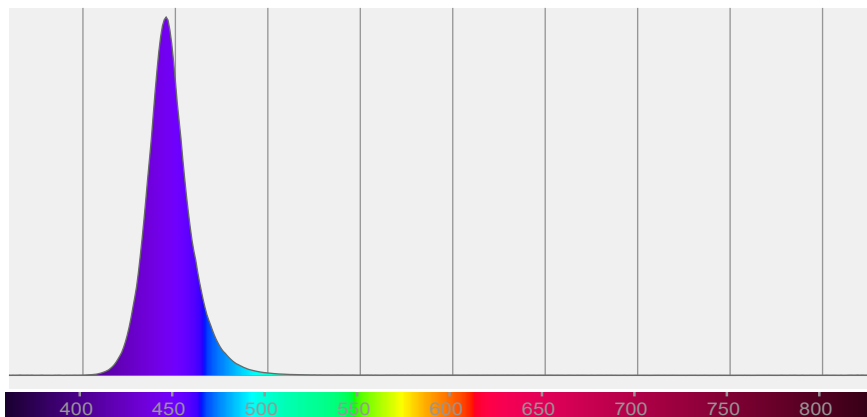

BEAM DETAILS



Beam angle 50%	Field angle 10%	Cut off angle 2,5%	Intensity ratio in 120° cone	Intensity ratio in 90° cone
48,3°	54,1°	56,9°	93,5%	91,4%

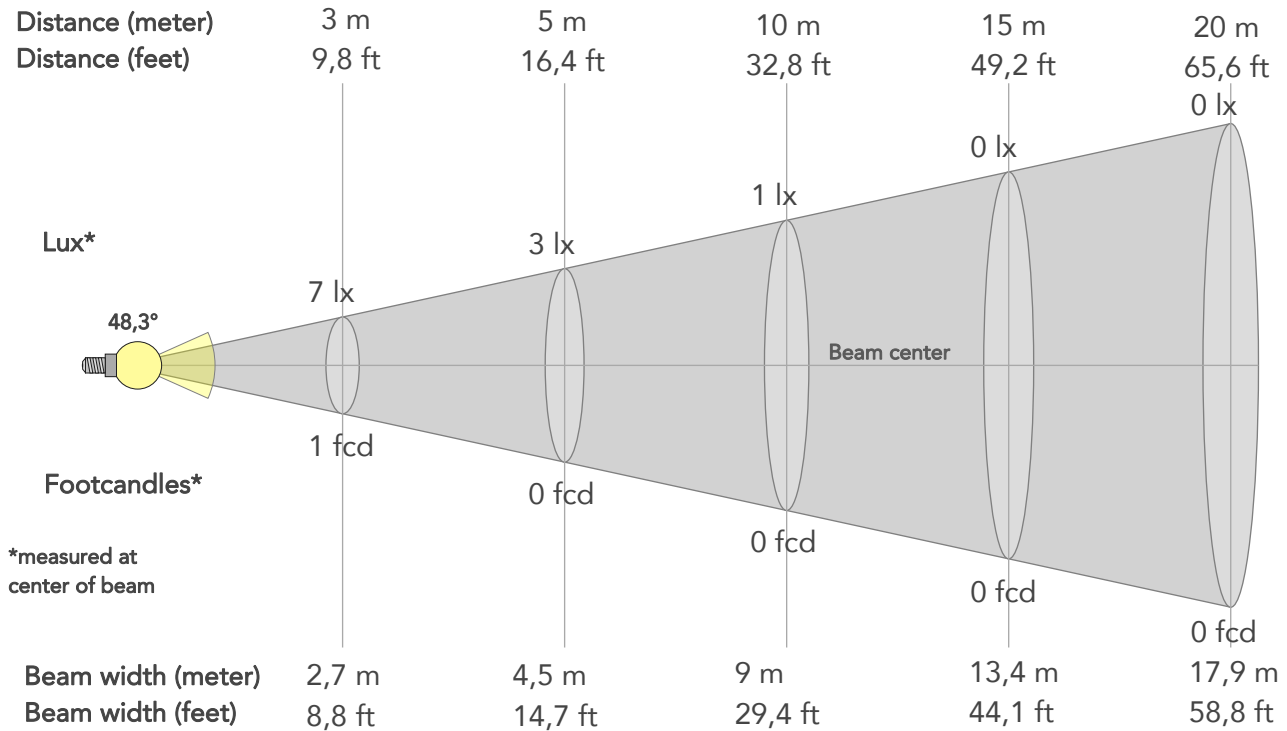

BEAM INTENSITIES AND WIDTHS

Distance	1m	2m	3m	4m	5m	7,5m	10m	15m	20m	25m	30m	40m	50m
Distance	3,3ft	6,6ft	9,8ft	13,1ft	16,4ft	24,6ft	32,8ft	49,2ft	65,6ft	82ft	98,4ft	131,2ft	164ft
Lux	65lx	16lx	7lx	4lx	3lx	1lx	1lx	0lx	0lx	0lx	0lx	0lx	0lx
Footcand.	6fcd	2fcd	1fcd	0fcd	0fcd	0fcd	0fcd	0fcd	0fcd	0fcd	0fcd	0fcd	0fcd
Beam wid.	0,9m	1,8m	2,7m	3,6m	4,5m	6,7m	9m	13,4m	17,9m	22,4m	26,9m	35,8m	44,8m
Beam wid.	3ft	5,9ft	8,8ft	11,7ft	14,7ft	22ft	29,4ft	44,1ft	58,8ft	73,5ft	88,2ft	117,5ft	146,9ft

LINEAR DISTRIBUTION DIAGRAM

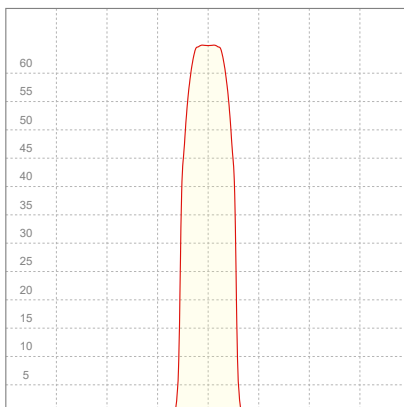

ELECTRICAL SPECIFICATIONS

Input voltage	Input current	Input power	Power FC	Efficiency
226V	0,178A	16,3W	0,41	2lm/W

ISO DIAGRAMS

ISO CANDELA DIAGRAM

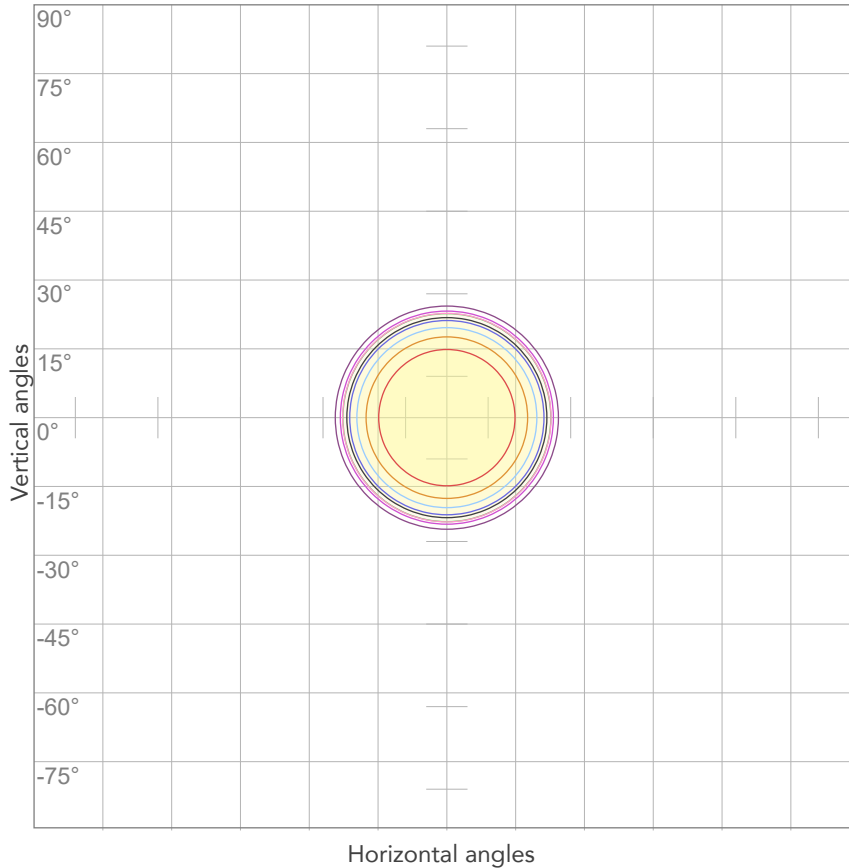

10%	6 cd
20%	13 cd
30%	19 cd
40%	26 cd
50%	32 cd
60%	39 cd
70%	45 cd
80%	52 cd

Conditions:

Number of c-planes: 2

Candela at center: 65 cd

ISO LUX DIAGRAM

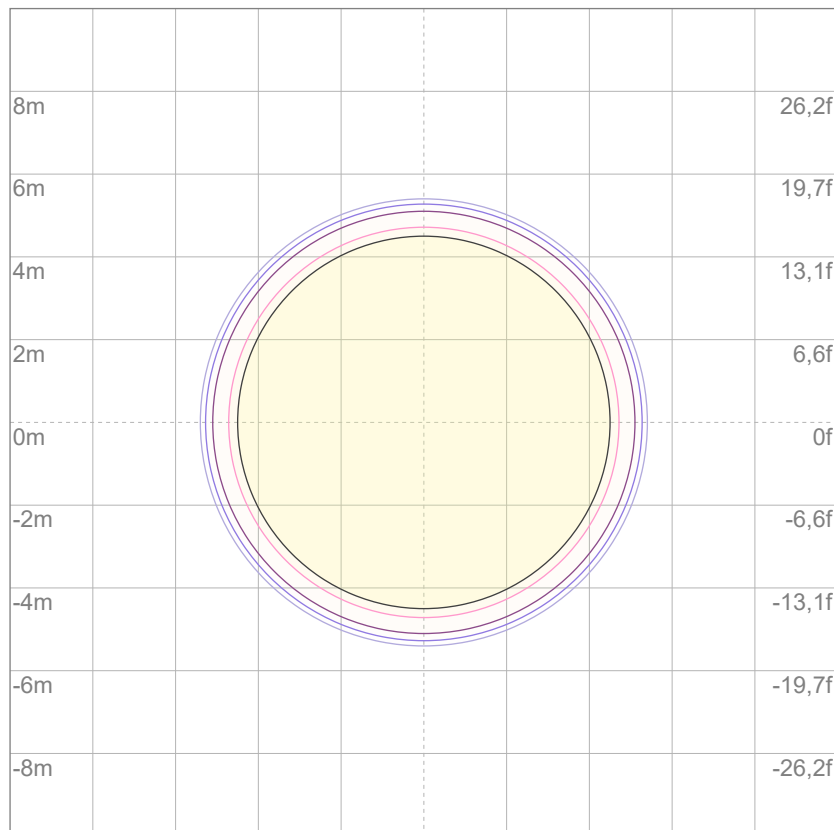

Mounting height: 10 meters (33 feet)

3%	19,5m lx
5%	32,4m lx
10%	64,9m lx
30%	0,195 lx
50%	0,324 lx

Conditions:

Number of c-planes: 2

Lux at center: 0,649 lx

Lux distribution on a surface when lamp is mounted at 10 meters from the surface.



Total lumen output:

212 lm

Peak candela output:

415 cd

Light quality:

CRI: 77,8

Color temperature:

3271 K

PRODUCT NAME:

ECLDISPLAY FC

MEASURAMENT CONDITIONS:

Beam angle:

Profile 50°

Target:

White

Operator:

Salvatore Giglio

Date and time:

07/02/2024 09:37:51

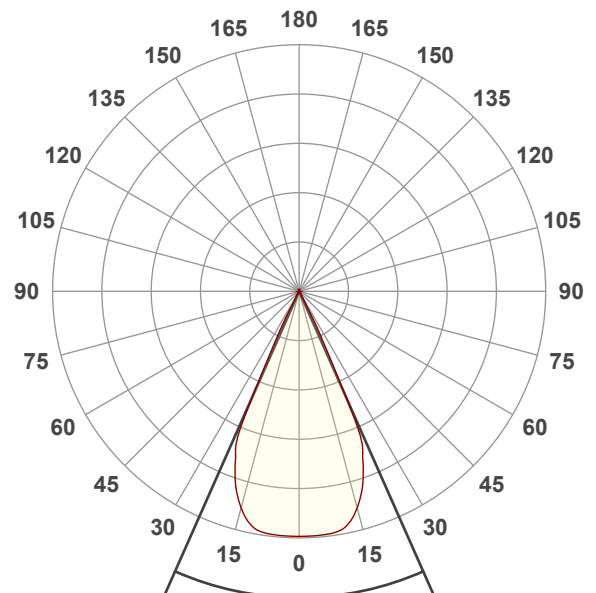

Beam angle 50%: 47,8°

Field angle 10%: 54,5°

Cut off angle 2.5%: 57,2°

Spectra

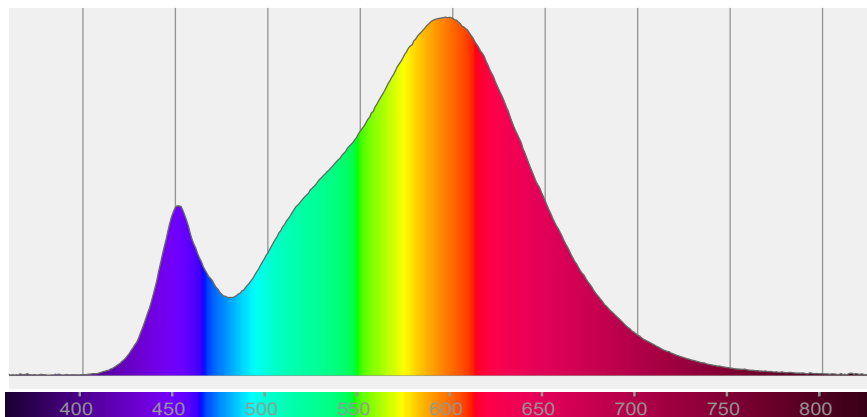

COLOR DETAILS

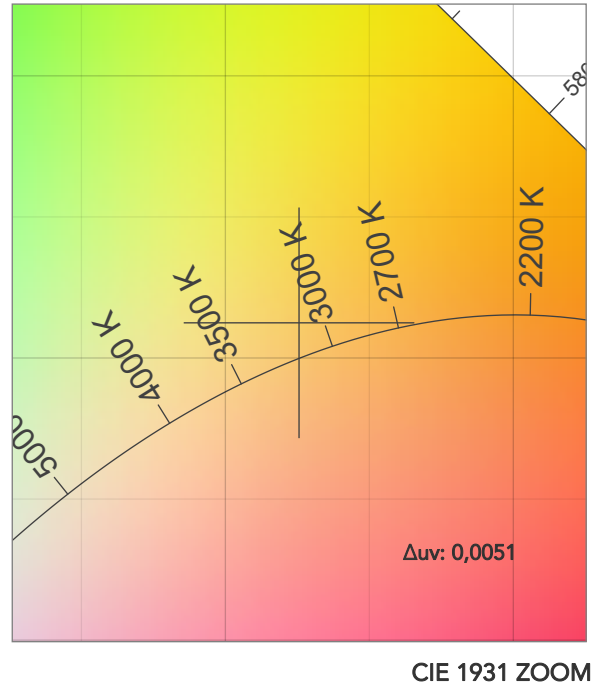
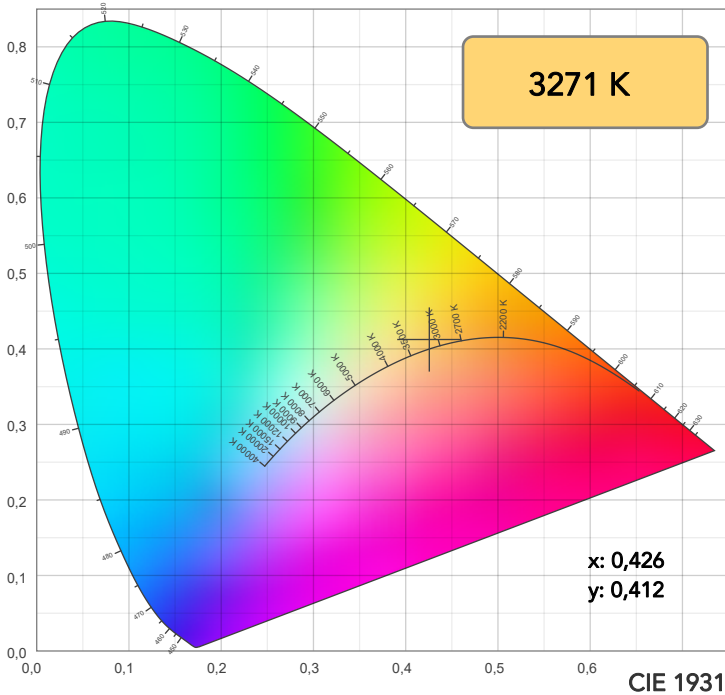

TM30: 82,4

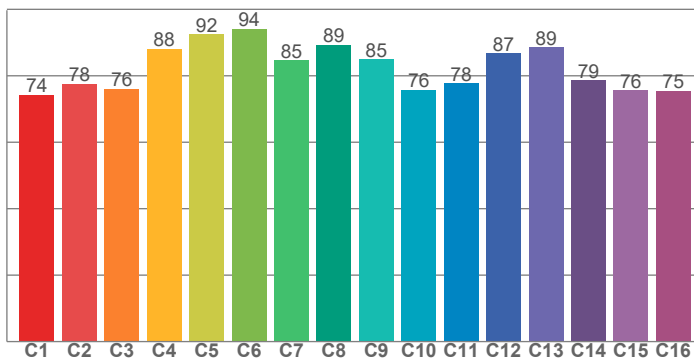

CRI: 77,8 (R1-R8)

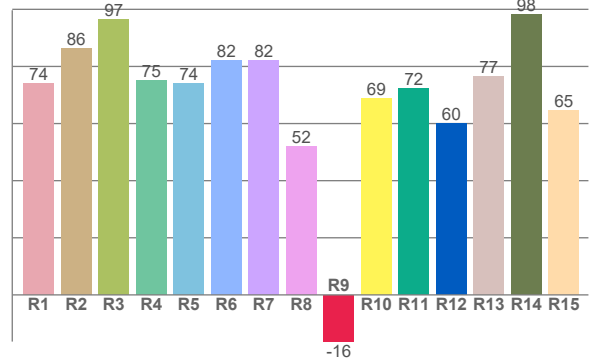

CQS: 78,7

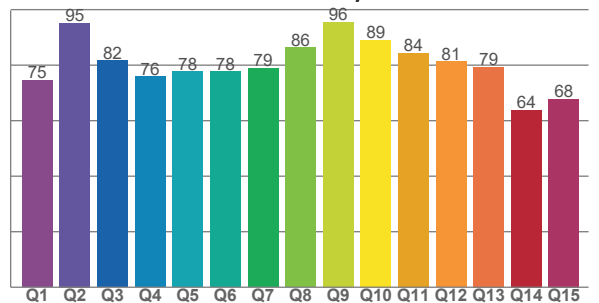

CRI R values, only R1-R8 are used to calculate final CRI value

R1	R2	R3	R4	R5	R6	R7	R8	R9	R10	R11	R12	R13	R14	R15
74,1	86,2	96,6	75,0	74,0	82,2	82,2	52,1	-16,4	68,7	72,2	59,9	76,7	98,2	64,6

TM30 C values, 16 binned values out of total of 99 C values

C1	C2	C3	C4	C5	C6	C7	C8	C9	C10	C11	C12	C13	C14	C15	C16
74,3	77,6	76,1	88,1	92,5	94,1	84,7	89,2	85,0	75,7	77,8	86,7	88,5	78,7	75,7	75,5

CQS Q values

Q1	Q2	Q3	Q4	Q5	Q6	Q7	Q8	Q9	Q10	Q11	Q12	Q13	Q14	Q15
74,5	95,2	81,7	75,9	77,6	77,7	78,9	86,3	95,6	89,0	84,3	81,4	79,3	63,8	67,9

COLOR PARAMETERS

Color temperature	Color rendering index	Red component	Color fidelity	Color gamut	Color quality scale	Television lighting index	Color coordinate cie 1931	Color coordinate cie 1931	Color deviation from black body
CCT	CRI	CRI R9	TM30 Rf	TM30 Rg	CQS	TLCI	x	y	Δuv
3271 K	77,8	-16,4	82,4	92,2	78,7	61	0,426	0,412	0,0051

TM30 DETAILS

Rf 82,4
Fidelity index Rf

Rg 92,2
Gammut index

Hue Bin	R _f	Graphic shifts (%)	
		Chroma	Hue
1	74	-15%	-1%
2	78	-11%	7%
3	76	-5%	12%
4	88	-1%	7%
5	92	0%	4%
6	94	0%	-3%
7	85	-7%	-7%
8	89	-7%	0%
9	85	-9%	6%
10	76	-6%	13%
12	87	7%	3%
13	89	4%	-6%
14	79	5%	-17%
15	76	-4%	-17%
16	75	-9%	-14%

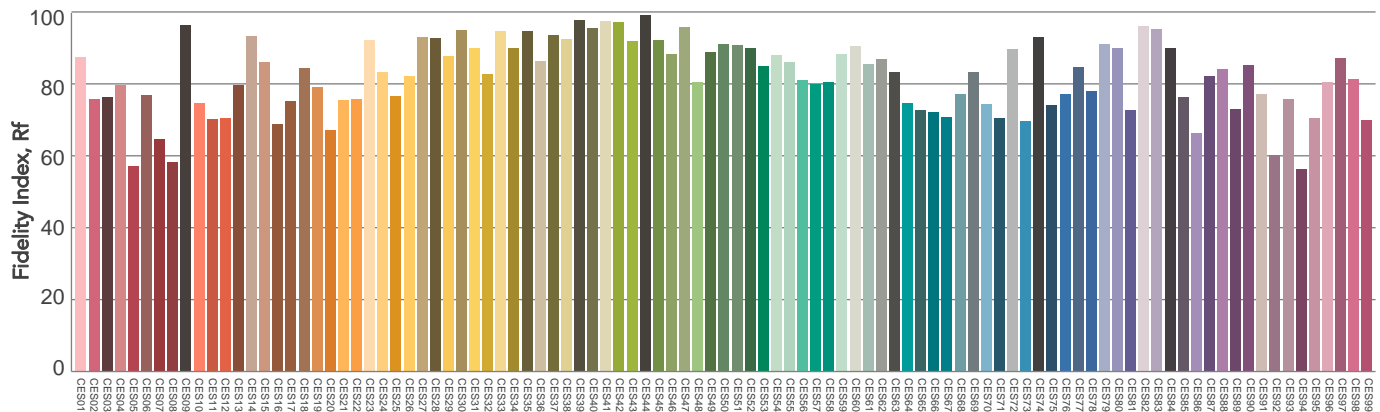
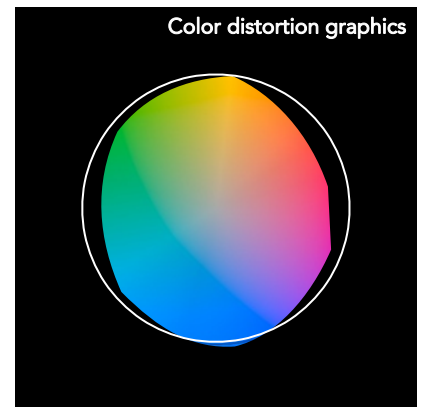
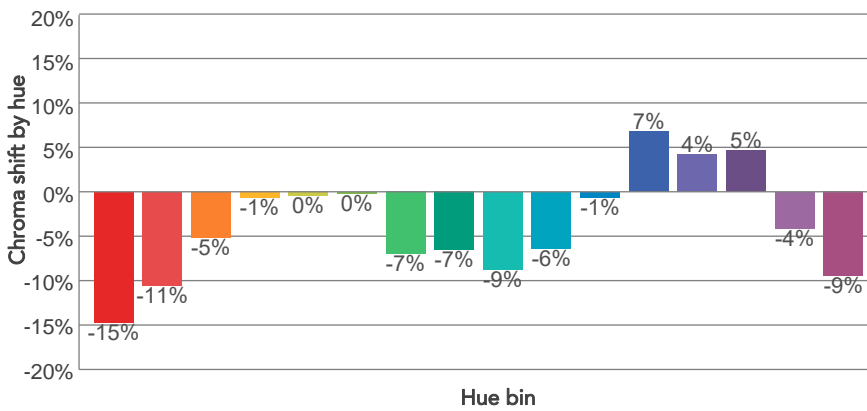
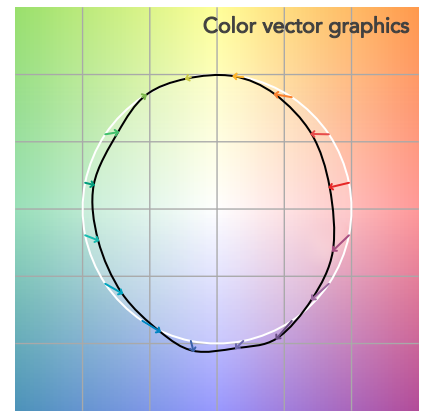
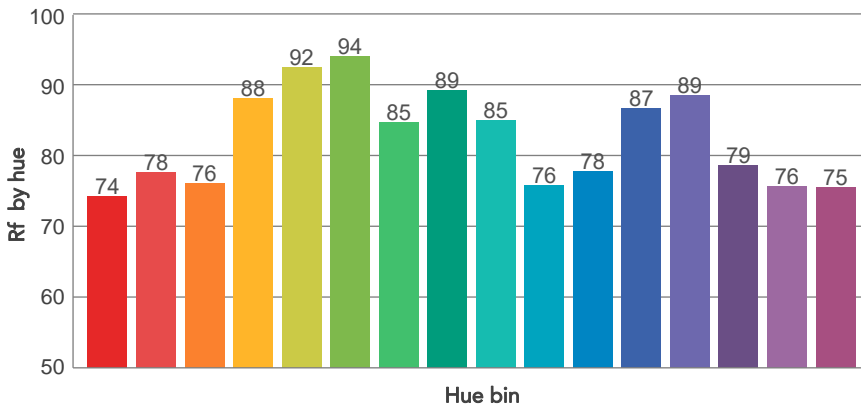
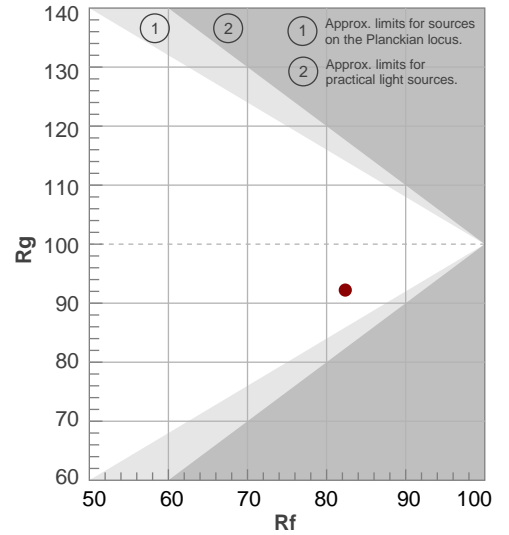

BEAM DETAILS



Beam angle 50%	Field angle 10%	Cut off angle 2,5%	Intensity ratio in 120° cone	Intensity ratio in 90° cone
47,8°	54,5°	57,2°	98,7%	98,2%

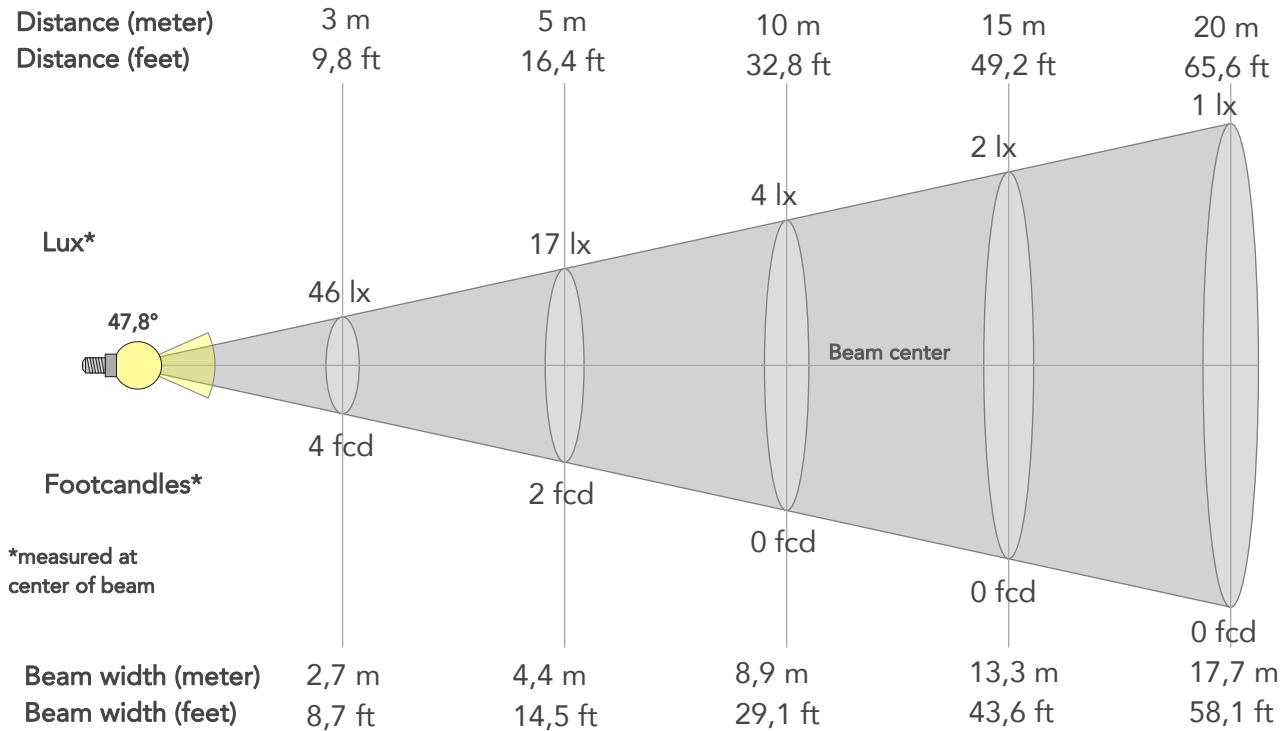

BEAM INTENSITIES AND WIDTHS

Distance	1m	2m	3m	4m	5m	7,5m	10m	15m	20m	25m	30m	40m	50m
Distance	3,3ft	6,6ft	9,8ft	13,1ft	16,4ft	24,6ft	32,8ft	49,2ft	65,6ft	82ft	98,4ft	131,2ft	164ft
Lux	415lx	104lx	46lx	26lx	17lx	7lx	4lx	2lx	1lx	1lx	0lx	0lx	0lx
Footcand.	39fcd	10fcd	4fcd	2fcd	2fcd	1fcd	0fcd	0fcd	0fcd	0fcd	0fcd	0fcd	0fcd
Beam wid.	0,9m	1,8m	2,7m	3,5m	4,4m	6,6m	8,9m	13,3m	17,7m	22,2m	26,6m	35,4m	44,3m
Beam wid.	2,9ft	5,8ft	8,7ft	11,6ft	14,5ft	21,8ft	29,1ft	43,6ft	58,1ft	72,7ft	87,2ft	116,3ft	145,3ft

LINEAR DISTRIBUTION DIAGRAM

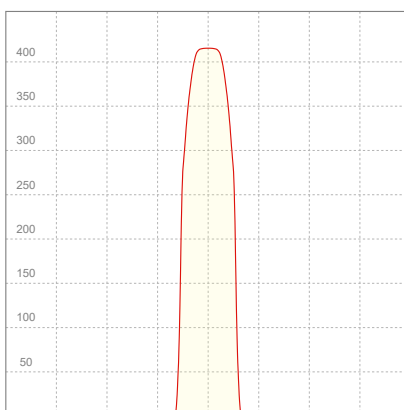

ELECTRICAL SPECIFICATIONS

Input voltage	Input current	Input power	Power FC	Efficiency
226V	0,208A	19,8W	0,42	11lm/W

ISO DIAGRAMS

ISO CANDELA DIAGRAM

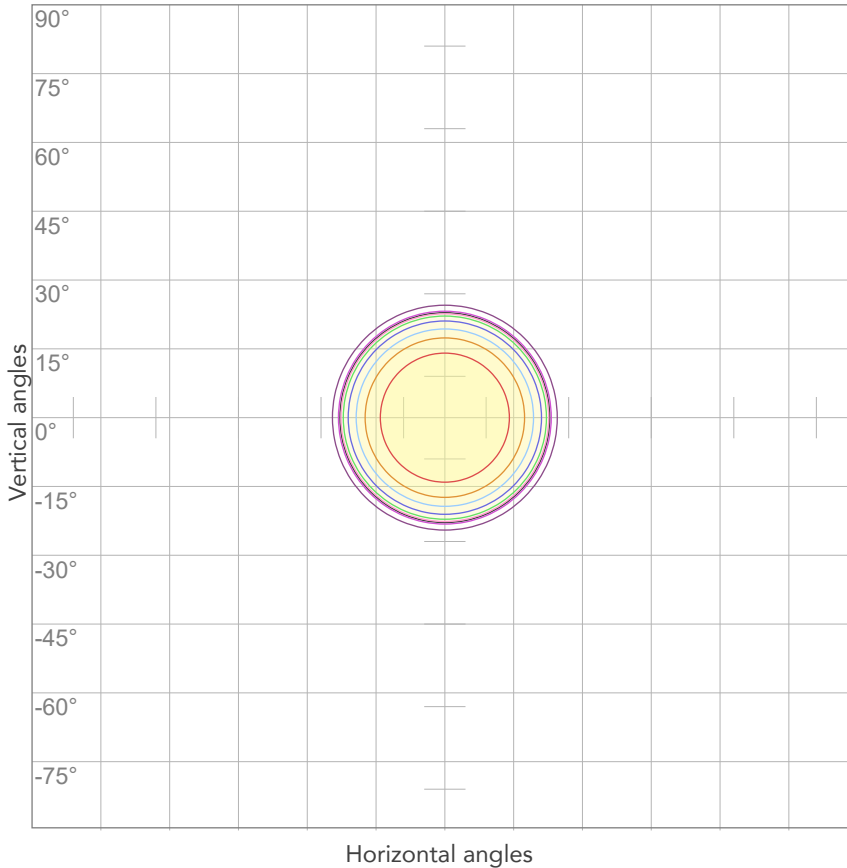

10%	42 cd
20%	83 cd
30%	125 cd
40%	166 cd
50%	208 cd
60%	249 cd
70%	291 cd
80%	332 cd

Conditions:

Number of c-planes: 2
Candela at center: 415 cd

ISO LUX DIAGRAM

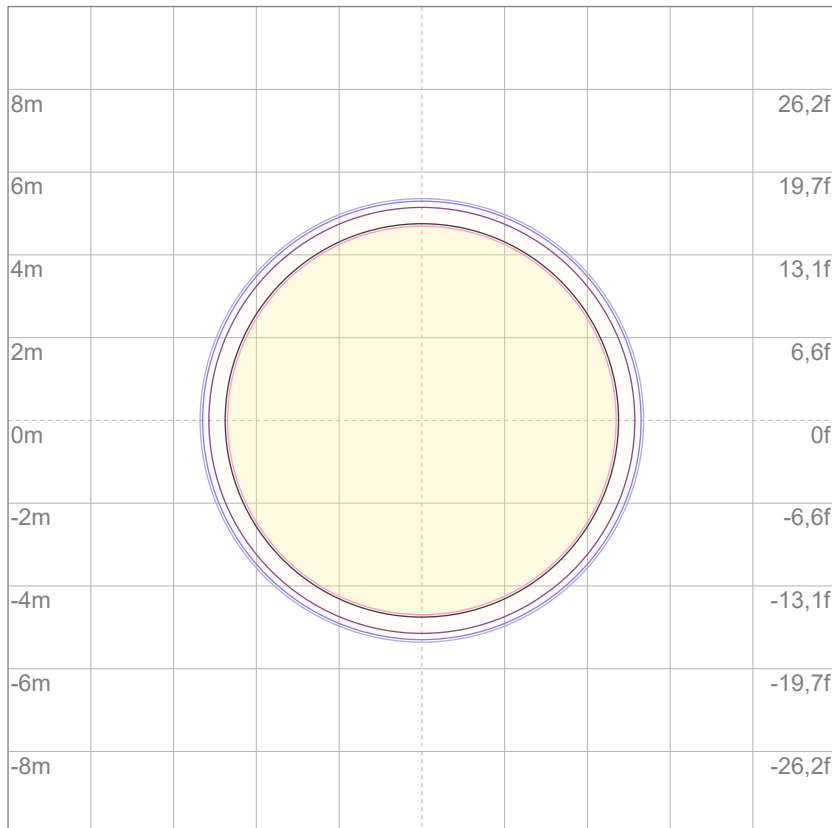

Mounting height: 10 meters (33 feet)

3%	0,125 lx
5%	0,208 lx
10%	0,415 lx
30%	1,25 lx
50%	2,08 lx

Conditions:

Number of c-planes: 2
Lux at center: 4,15 lx

Lux distribution on a surface when lamp is mounted at 10 meters from the surface.



Total lumen output:

251 lm

Peak candela output:

494 cd

Light quality:

CRI: 94,8

Color temperature:

2770 K

PRODUCT NAME:

ECLDISPLAY FC

MEASURAMENT CONDITIONS:

Beam angle:

Profile 50°

Target:

2800K

Operator:

Salvatore Giglio

Date and time:

07/02/2024 09:39:13

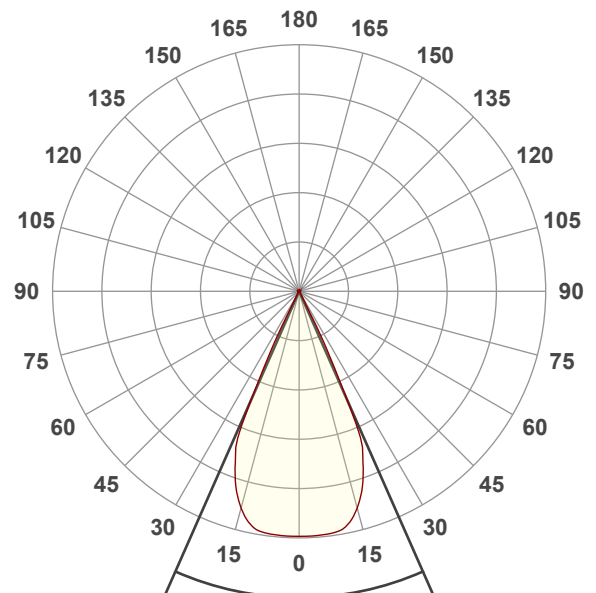

Beam angle 50%: 47,7°

Field angle 10%: 54,4°

Cut off angle 2.5%: 56,1°

Spectra

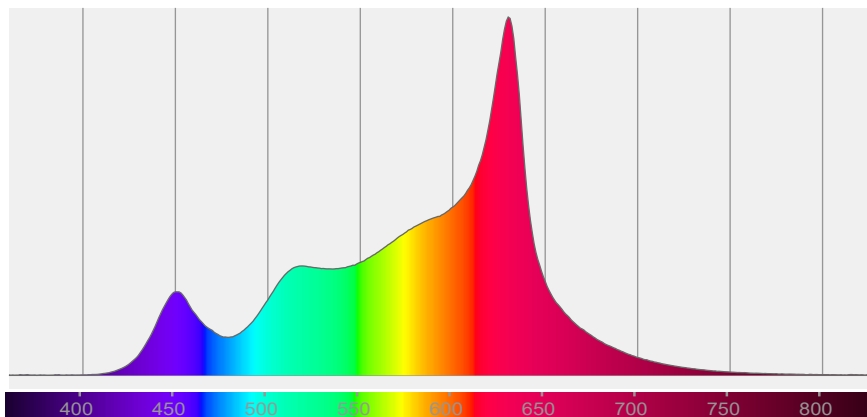

COLOR DETAILS

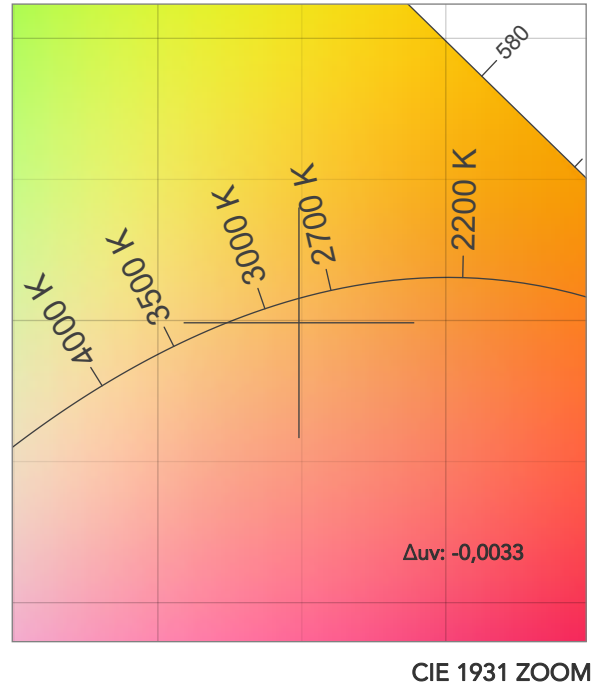
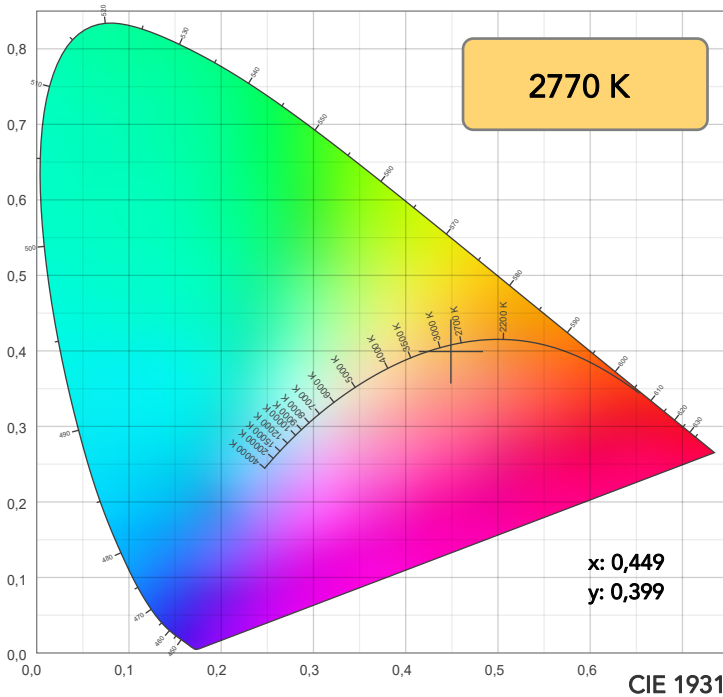

TM30: 92,6

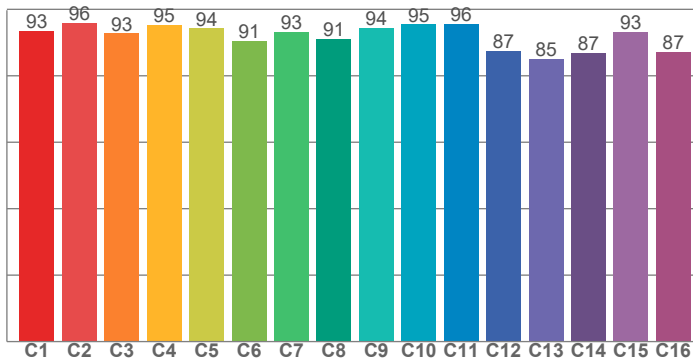

CRI: 94,8 (R1-R8)

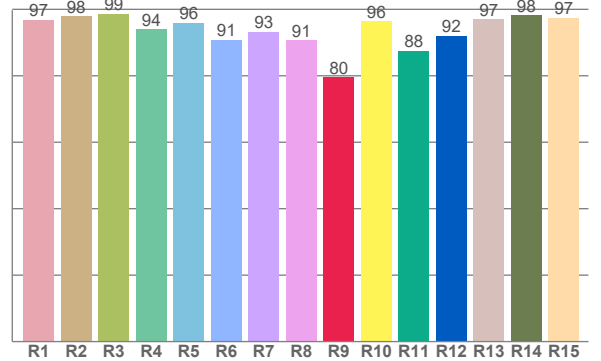

CQS: 92,7

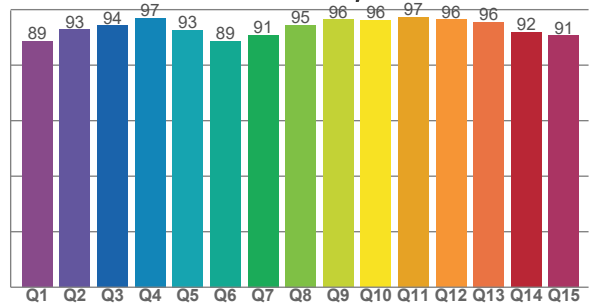

CRI R values, only R1-R8 are used to calculate final CRI value

R1	R2	R3	R4	R5	R6	R7	R8	R9	R10	R11	R12	R13	R14	R15
96,9	97,9	98,6	94,0	96,0	90,8	93,2	90,7	79,6	96,5	87,6	92,0	96,9	98,1	97,5

TM30 C values, 16 binned values out of total of 99 C values

C1	C2	C3	C4	C5	C6	C7	C8	C9	C10	C11	C12	C13	C14	C15	C16
93,4	96,0	92,8	95,3	94,3	90,5	93,1	91,1	94,4	95,4	95,7	87,4	85,1	87,0	93,3	87,3

CQS Q values

Q1	Q2	Q3	Q4	Q5	Q6	Q7	Q8	Q9	Q10	Q11	Q12	Q13	Q14	Q15
88,6	92,8	94,3	96,9	92,6	88,6	90,8	94,5	96,4	96,2	97,3	96,4	95,6	91,8	90,6

COLOR PARAMETERS

Color temperature	Color rendering index	Red component	Color fidelity	Color gamut	Color quality scale	Television lighting index	Color coordinate cie 1931	Color coordinate cie 1931	Color deviation from black body
CCT	CRI	CRI R9	TM30 Rf	TM30 Rg	CQS	TLCI	x	y	Δuv
2770 K	94,8	79,6	92,6	103,6	92,7	81	0,449	0,399	-0,0033

TM30 DETAILS

Rf 92,6
Fidelity index Rf

Rg 103,6
Gammut index

Hue Bin	R _f	Graphic shifts (%)	
		Chroma	Hue
1	93	-3%	-1%
2	96	-1%	2%
3	93	1%	3%
4	95	2%	1%
5	94	3%	3%
6	91	6%	2%
7	93	3%	-2%
8	91	5%	-2%
9	94	2%	-2%
10	95	1%	-2%
11	96	2%	0%
12	87	5%	-5%
13	85	4%	-11%
14	87	2%	-10%
15	93	0%	-4%
16	87	-3%	-9%

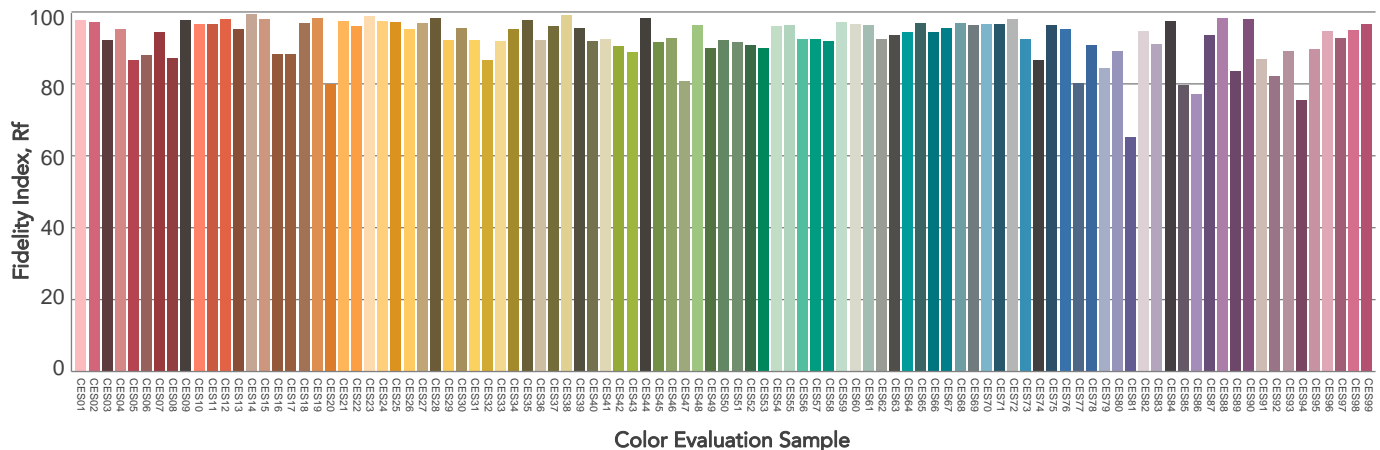
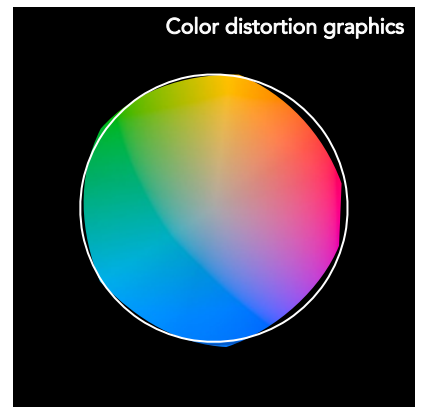
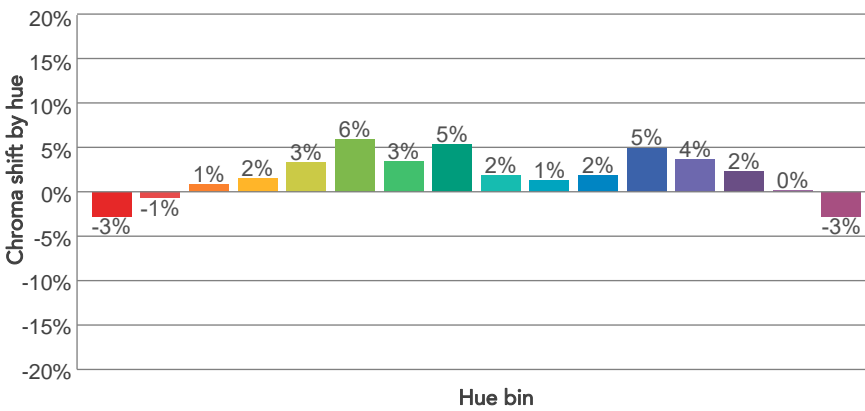
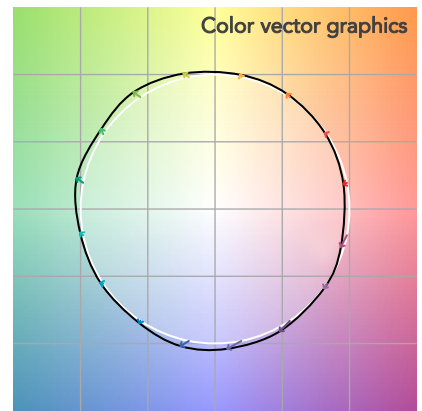
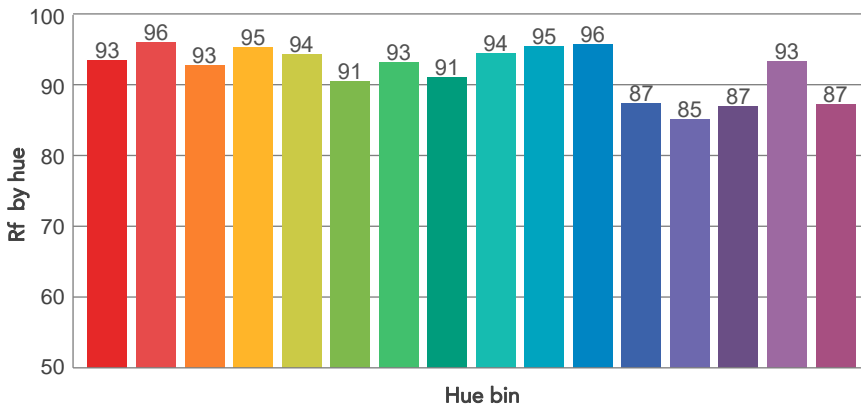
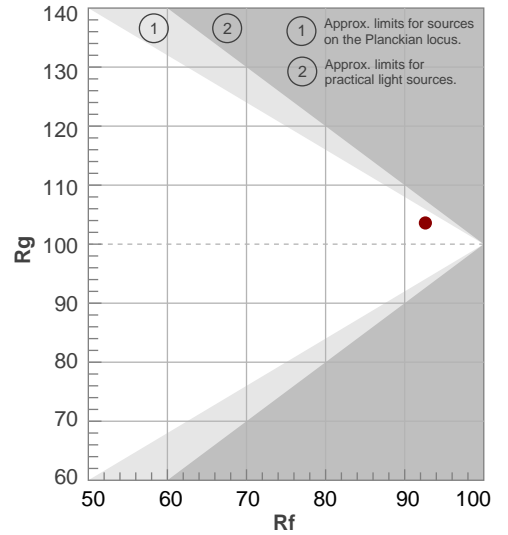

BEAM DETAILS



Beam angle 50%	Field angle 10%	Cut off angle 2,5%	Intensity ratio in 120° cone	Intensity ratio in 90° cone
47,7°	54,4°	56,1°	98,9%	98,5%

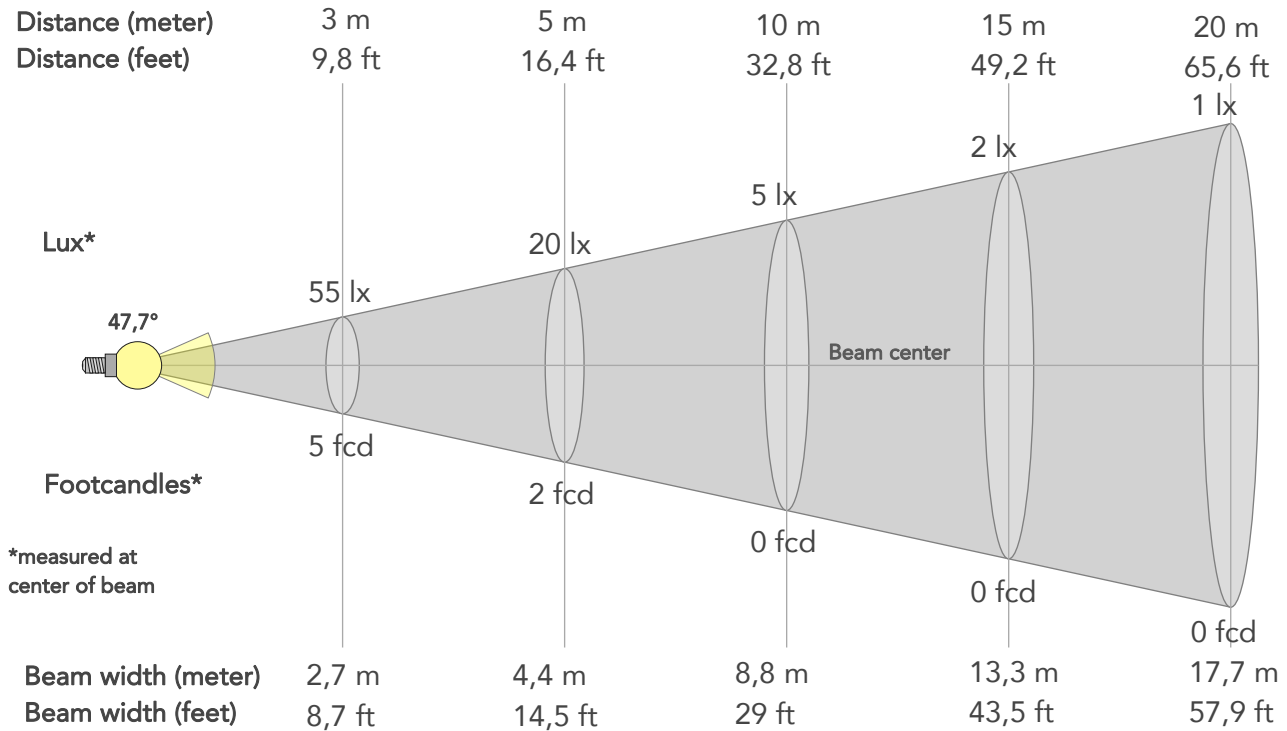

BEAM INTENSITIES AND WIDTHS

Distance	1m	2m	3m	4m	5m	7,5m	10m	15m	20m	25m	30m	40m	50m
Distance	3,3ft	6,6ft	9,8ft	13,1ft	16,4ft	24,6ft	32,8ft	49,2ft	65,6ft	82ft	98,4ft	131,2ft	164ft
Lux	494lx	124lx	55lx	31lx	20lx	9lx	5lx	2lx	1lx	1lx	1lx	0lx	0lx
Footcand.	46fcd	11fcd	5fcd	3fcd	2fcd	1fcd	0fcd	0fcd	0fcd	0fcd	0fcd	0fcd	0fcd
Beam wid.	0,9m	1,8m	2,7m	3,5m	4,4m	6,6m	8,8m	13,3m	17,7m	22,1m	26,5m	35,3m	44,2m
Beam wid.	2,9ft	5,8ft	8,7ft	11,6ft	14,5ft	21,7ft	29ft	43,5ft	57,9ft	72,4ft	86,9ft	115,9ft	144,9ft

LINEAR DISTRIBUTION DIAGRAM

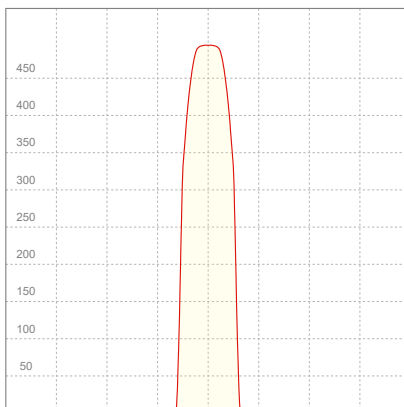

ELECTRICAL SPECIFICATIONS

Input voltage	Input current	Input power	Power FC	Efficiency
226V	0,262A	25,5W	0,43	10lm/W

ISO DIAGRAMS

ISO CANDELA DIAGRAM

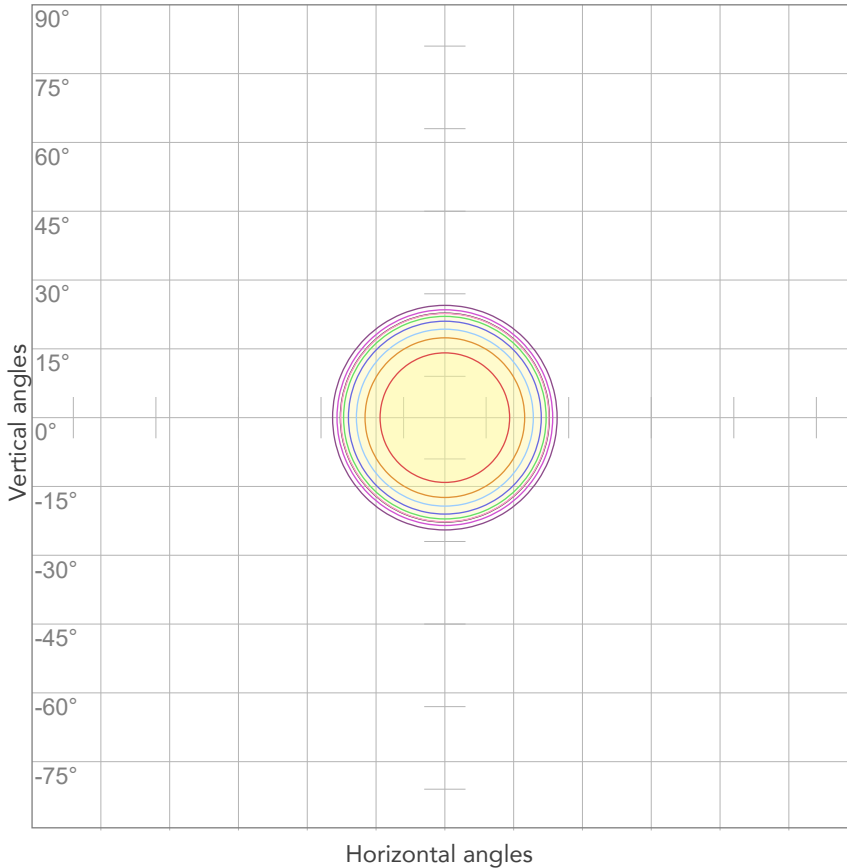

10%	49 cd
20%	99 cd
30%	148 cd
40%	198 cd
50%	247 cd
60%	297 cd
70%	346 cd
80%	395 cd

Conditions:

Number of c-planes: 2

Candela at center: 494 cd

ISO LUX DIAGRAM

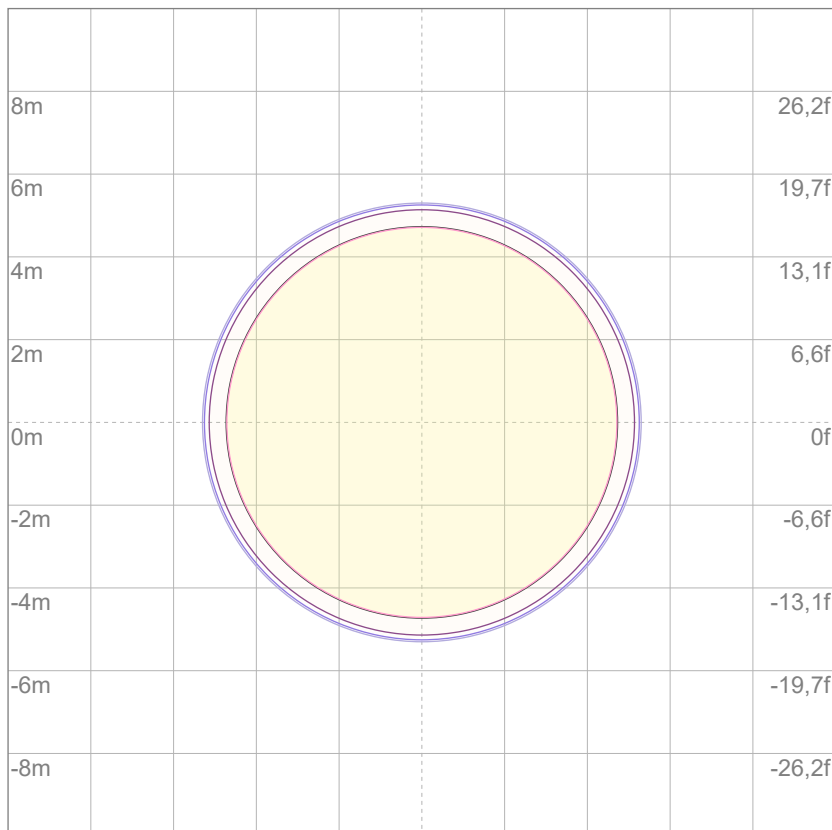

3%	0,148 lx
5%	0,247 lx
10%	0,494 lx
30%	1,48 lx
50%	2,47 lx

Conditions:

Number of c-planes: 2

Lux at center: 4,94 lx

Lux distribution on a surface when lamp is mounted at 10 meters from the surface.



Total lumen output:

256 lm

Peak candela output:

504 cd

Light quality:

CRI: 94,9

Color temperature:

3216 K

PRODUCT NAME:

ECLDISPLAY FC

MEASURAMENT CONDITIONS:

Beam angle:

Profile 50°

Target:

3200K

Operator:

Salvatore Giglio

Date and time:

07/02/2024 09:42:04

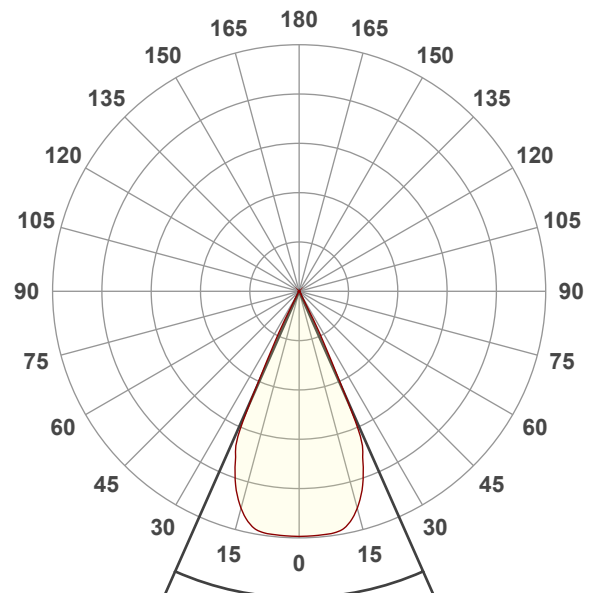

Beam angle 50%: 47,8°

Field angle 10%: 54,5°

Cut off angle 2.5%: 56,8°

Spectra

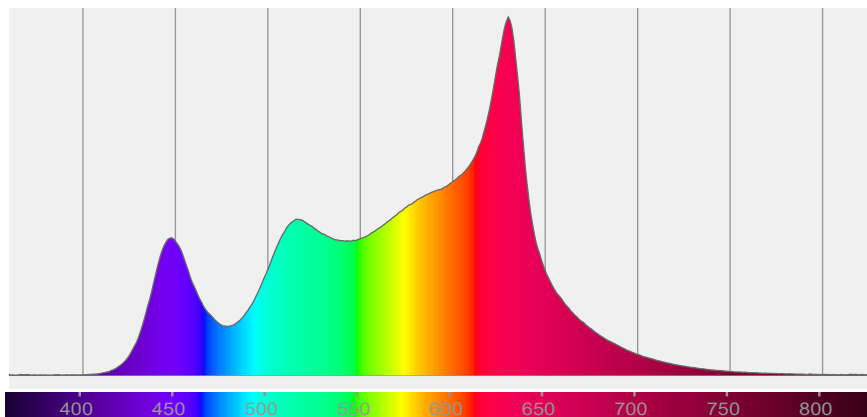

COLOR DETAILS

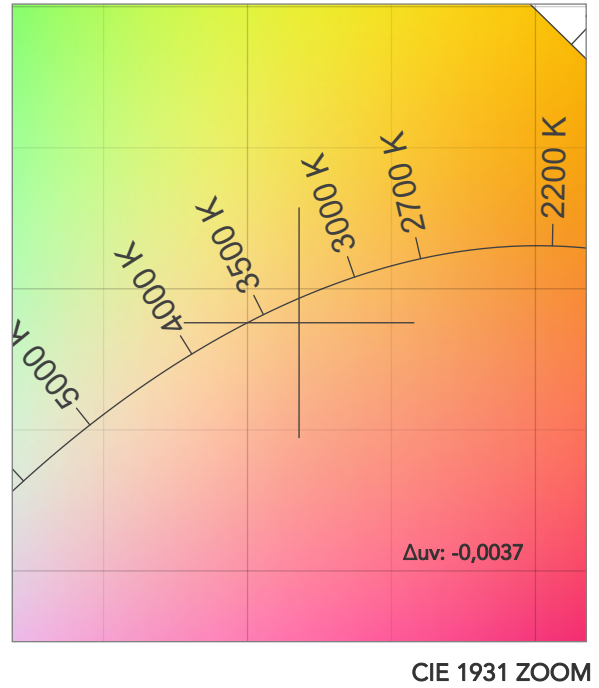
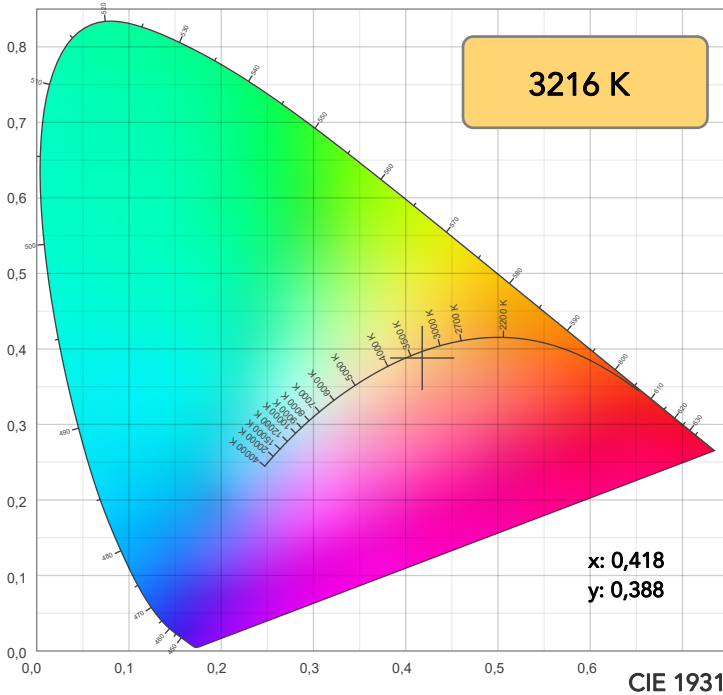

TM30: 92,6

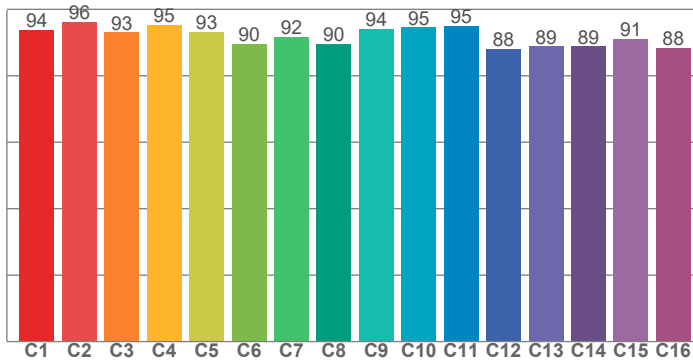

CRI: 94,9 (R1-R8)

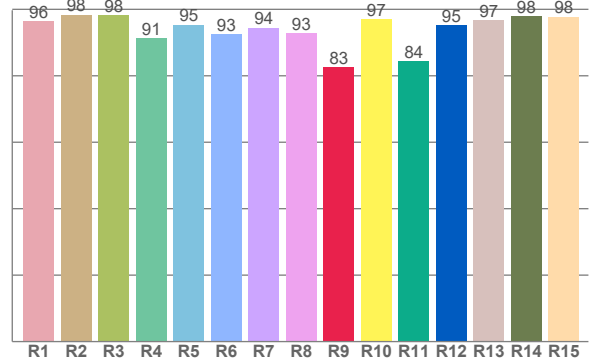

CRI R values, only R1-R8 are used to calculate final CRI value

R1	R2	R3	R4	R5	R6	R7	R8	R9	R10	R11	R12	R13	R14	R15
96,4	98,4	98,3	91,4	95,4	92,5	94,4	92,8	82,6	97,0	84,4	95,2	96,8	98,0	97,7

TM30 C values, 16 binned values out of total of 99 C values

C1	C2	C3	C4	C5	C6	C7	C8	C9	C10	C11	C12	C13	C14	C15	C16
93,8	96,1	93,0	95,3	93,2	89,6	91,6	89,6	94,1	94,5	95,0	88,2	88,8	88,9	91,0	88,4

CQS Q values

Q1	Q2	Q3	Q4	Q5	Q6	Q7	Q8	Q9	Q10	Q11	Q12	Q13	Q14	Q15
90,4	95,9	93,8	97,0	91,3	87,5	92,4	97,1	98,0	96,7	98,1	98,1	97,1	93,4	92,1

CQS: 93,5

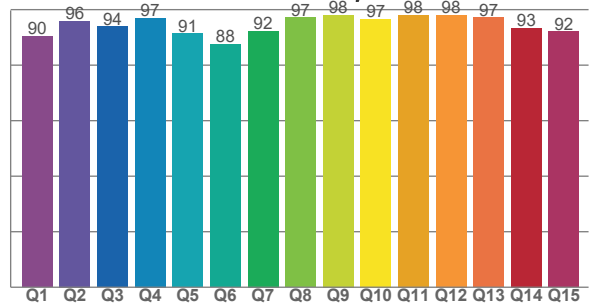

COLOR PARAMETERS

Color temperature	Color rendering index	Red component	Color fidelity	Color gamut	Color quality scale	Television lighting index	Color coordinate cie 1931	Color coordinate cie 1931	Color deviation from black body
CCT	CRI	CRI R9	TM30 Rf	TM30 Rg	CQS	TLCI	x	y	Δuv
3216 K	94,9	82,6	92,6	104,6	93,5	83	0,418	0,388	-0,0037

TM30 DETAILS

Rf 92,6
Fidelity index Rf

Rg 104,6
Gammut index

Hue Bin	R _f	Graphic shifts (%)	
		Chroma	Hue
1	94	-2%	-1%
2	96	-1%	1%
3	93	1%	3%
4	95	2%	2%
5	93	3%	3%
6	90	6%	2%
7	92	5%	-2%
8	90	6%	-3%
9	94	2%	-3%
10	95	0%	-3%
11	95	1%	1%
12	88	5%	-4%
13	89	4%	-8%
14	89	3%	-8%
15	91	1%	-5%
16	88	0%	-9%

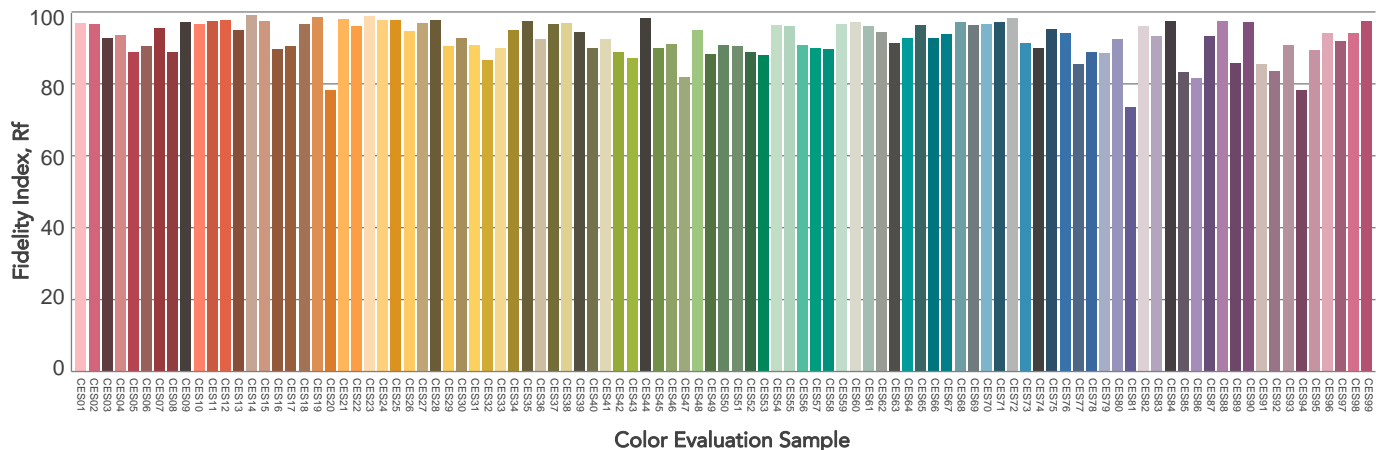
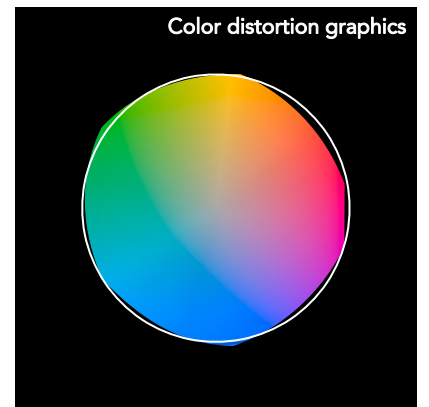
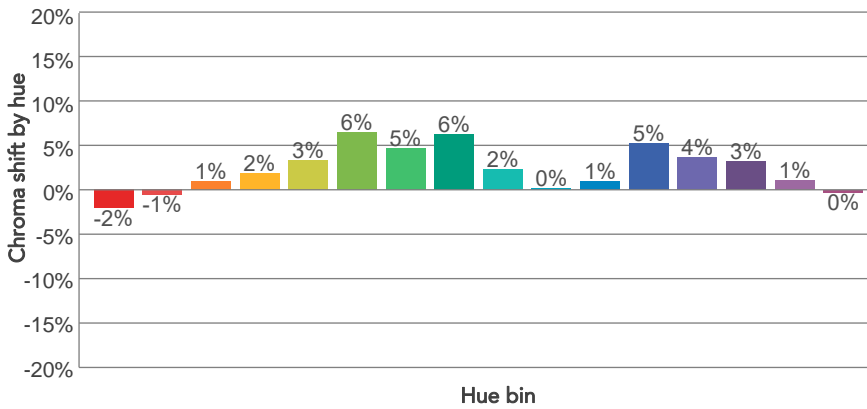
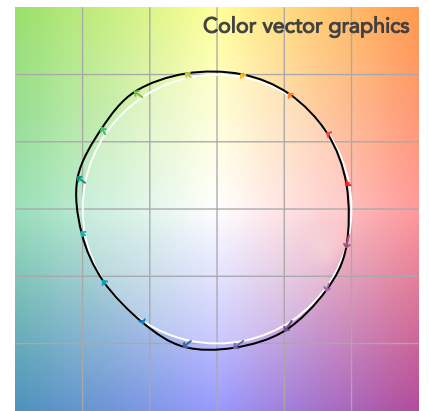
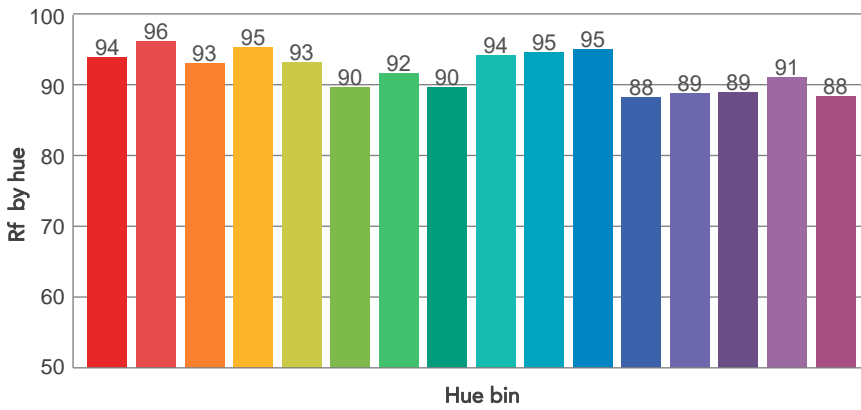
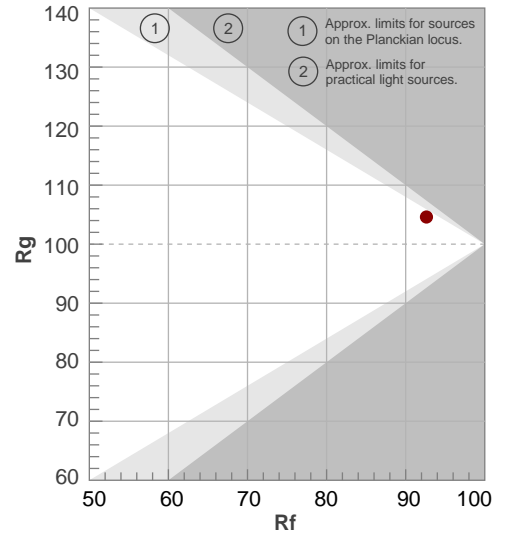

BEAM DETAILS



Beam angle 50%	Field angle 10%	Cut off angle 2,5%	Intensity ratio in 120° cone	Intensity ratio in 90° cone
47,8°	54,5°	56,8°	98,9%	98,6%

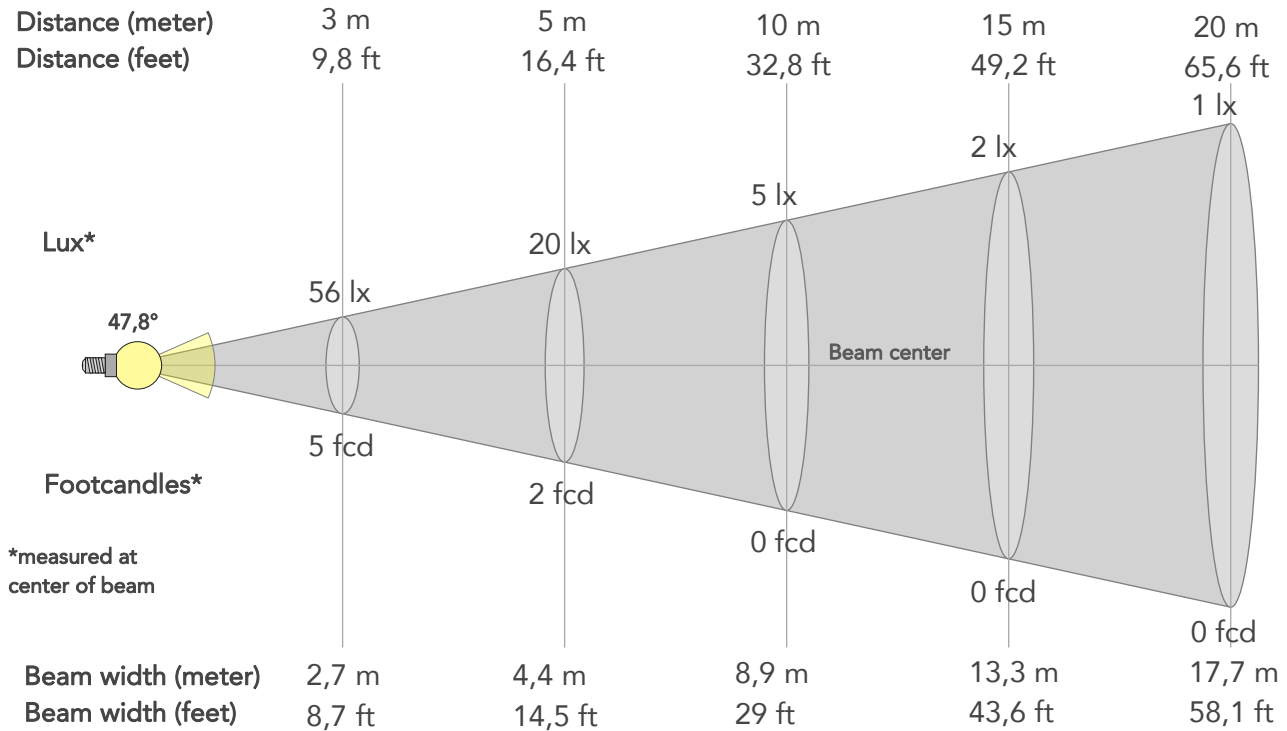

BEAM INTENSITIES AND WIDTHS

Distance	1m	2m	3m	4m	5m	7,5m	10m	15m	20m	25m	30m	40m	50m
Distance	3,3ft	6,6ft	9,8ft	13,1ft	16,4ft	24,6ft	32,8ft	49,2ft	65,6ft	82ft	98,4ft	131,2ft	164ft
Lux	504lx	126lx	56lx	32lx	20lx	9lx	5lx	2lx	1lx	1lx	1lx	0lx	0lx
Footcand.	47fcd	12fcd	5fcd	3fcd	2fcd	1fcd	0fcd	0fcd	0fcd	0fcd	0fcd	0fcd	0fcd
Beam wid.	0,9m	1,8m	2,7m	3,5m	4,4m	6,6m	8,9m	13,3m	17,7m	22,1m	26,6m	35,4m	44,3m
Beam wid.	2,9ft	5,8ft	8,7ft	11,6ft	14,5ft	21,8ft	29ft	43,6ft	58,1ft	72,6ft	87,1ft	116,1ft	145,2ft

LINEAR DISTRIBUTION DIAGRAM

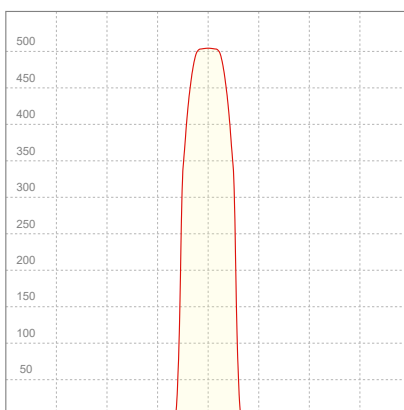

ELECTRICAL SPECIFICATIONS

Input voltage	Input current	Input power	Power FC	Efficiency
226V	0,261A	26,4W	0,45	10lm/W

ISO DIAGRAMS

ISO CANDELA DIAGRAM

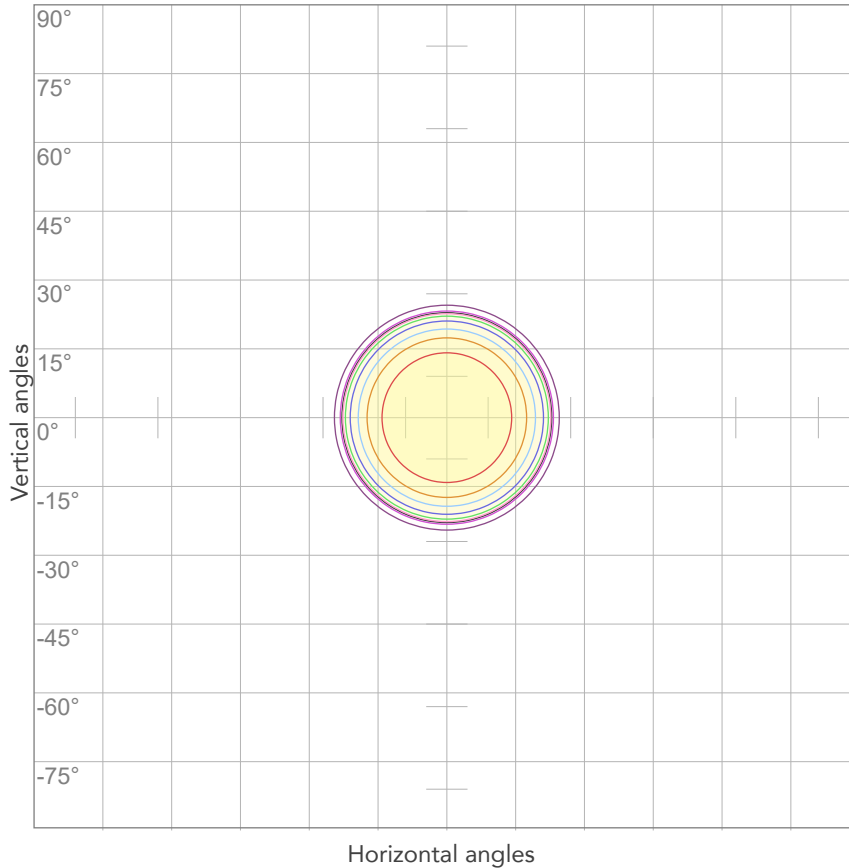

10%	50 cd
20%	101 cd
30%	151 cd
40%	202 cd
50%	252 cd
60%	303 cd
70%	353 cd
80%	403 cd

Conditions:

Number of c-planes: 2
Candela at center: 504 cd

ISO LUX DIAGRAM

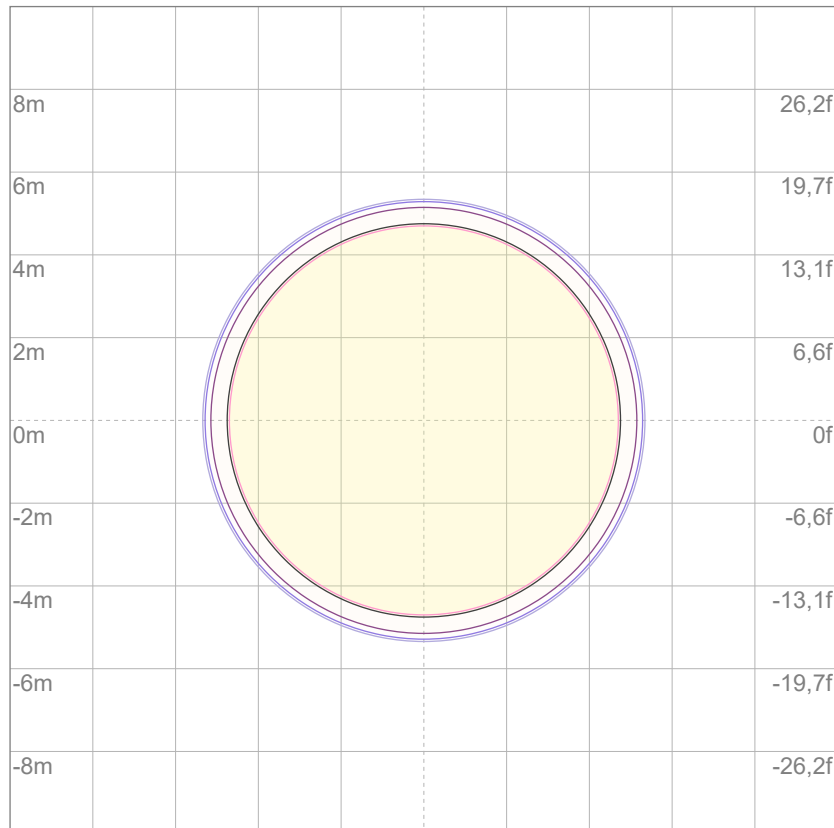

3%	0,151 lx
5%	0,252 lx
10%	0,504 lx
30%	1,51 lx
50%	2,52 lx

Conditions:

Number of c-planes: 2
Lux at center: 5,04 lx

Lux distribution on a surface when lamp is mounted at 10 meters from the surface.

Mounting height: 10 meters (33 feet)



Total lumen output:

264 lm

Peak candela output:

519 cd

Light quality:

CRI: 94,1

Color temperature:

4062 K

PRODUCT NAME:
ECLDISPLAY FC

MEASURAMENT CONDITIONS:

Beam angle:
Profile 50°

Target:
4000K

Operator:
Salvatore Giglio

Date and time:
07/02/2024 09:43:54

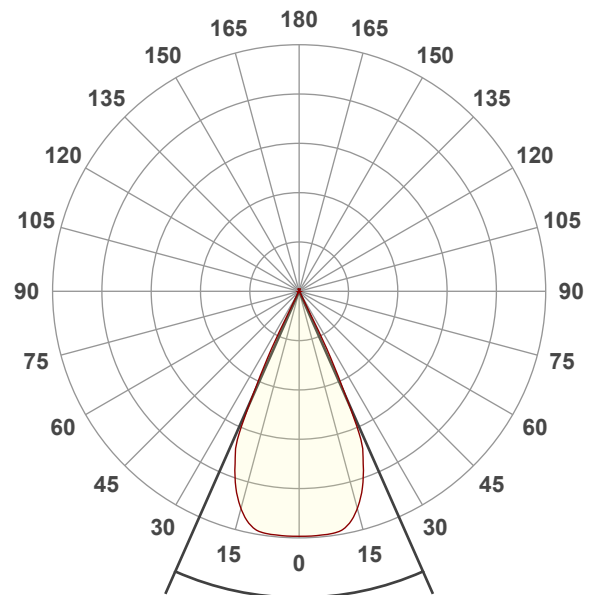

Beam angle 50%: 47,7°
Field angle 10%: 54,3°
Cut off angle 2.5%: 55,6°

Spectra

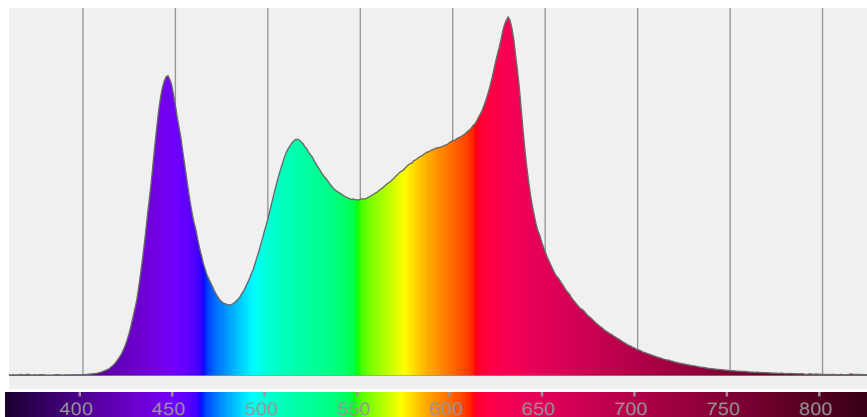

COLOR DETAILS

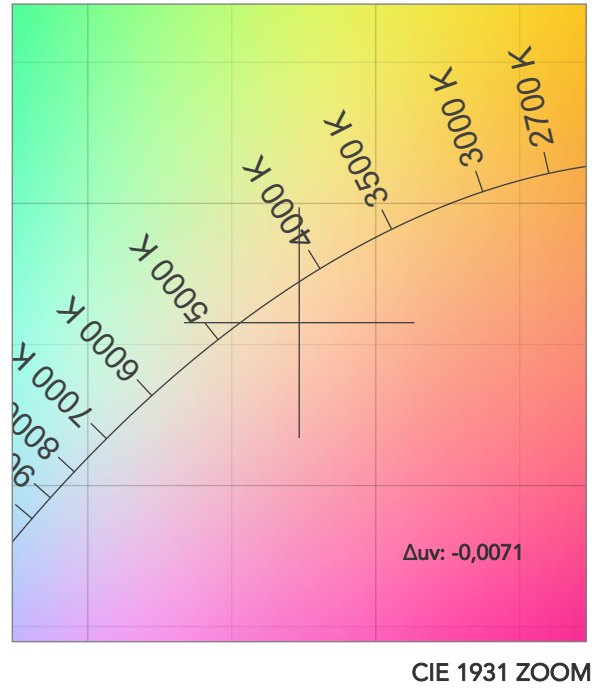
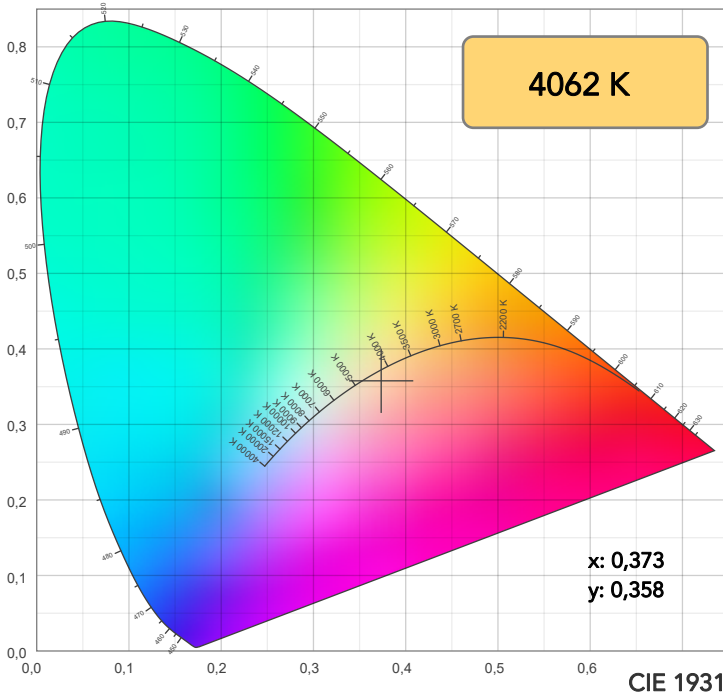

TM30: 91,5

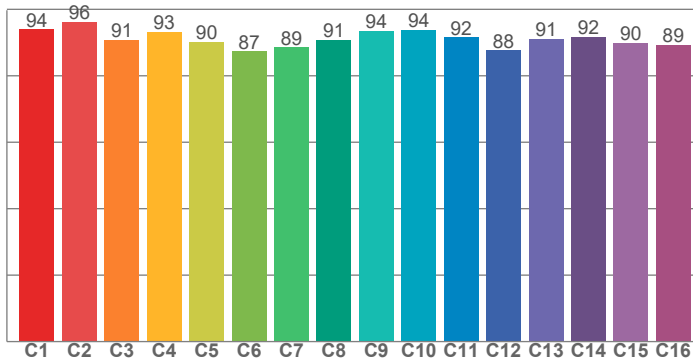

CRI: 94,1 (R1-R8)

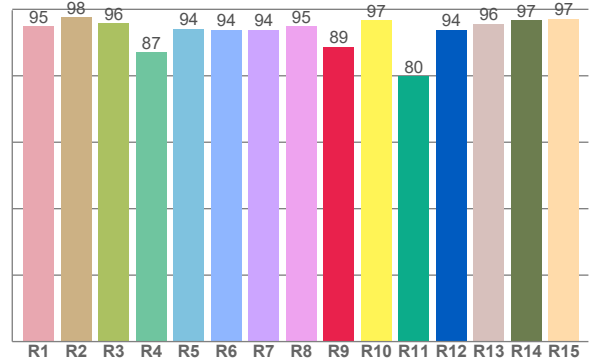

CRI R values, only R1-R8 are used to calculate final CRI value

R1	R2	R3	R4	R5	R6	R7	R8	R9	R10	R11	R12	R13	R14	R15
95,0	97,6	95,8	87,2	94,2	93,8	93,9	95,0	88,7	96,7	79,9	93,8	95,7	96,7	97,1

TM30 C values, 16 binned values out of total of 99 C values

C1	C2	C3	C4	C5	C6	C7	C8	C9	C10	C11	C12	C13	C14	C15	C16
93,9	96,2	90,7	93,3	90,2	87,3	88,5	90,9	93,6	93,7	91,5	87,6	91,2	91,8	90,0	89,4

CQS Q values

Q1	Q2	Q3	Q4	Q5	Q6	Q7	Q8	Q9	Q10	Q11	Q12	Q13	Q14	Q15
93,1	98,2	89,7	98,1	91,9	87,3	93,9	99,7	97,5	95,0	98,6	97,5	96,9	95,0	94,7

CQS: 94,1

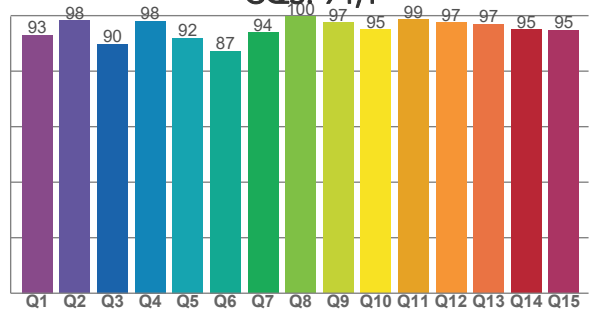

COLOR PARAMETERS

Color temperature	Color rendering index	Red component	Color fidelity	Color gamut	Color quality scale	Television lighting index	Color coordinate cie 1931	Color coordinate cie 1931	Color deviation from black body
CCT	CRI	CRI R9	TM30 Rf	TM30 Rg	CQS	TLCI	x	y	Δuv
4062 K	94,1	88,7	91,5	106,3	94,1	80	0,373	0,358	-0,0071

TM30 DETAILS

Rf 91,5
Fidelity index Rf

Rg 106,3
Gammut index

Hue Bin	R _f	Graphic shifts (%)	
		Chroma	Hue
1	94	-2%	-2%
2	96	0%	1%
3	91	1%	5%
4	93	2%	3%
5	90	5%	4%
6	87	8%	3%
7	89	8%	-1%
8	91	5%	-2%
9	94	2%	-3%
10	94	-2%	-3%
11	92	2%	4%
12	88	4%	4%
13	91	6%	-3%
14	92	5%	2%
15	90	4%	-6%
16	89	2%	-7%

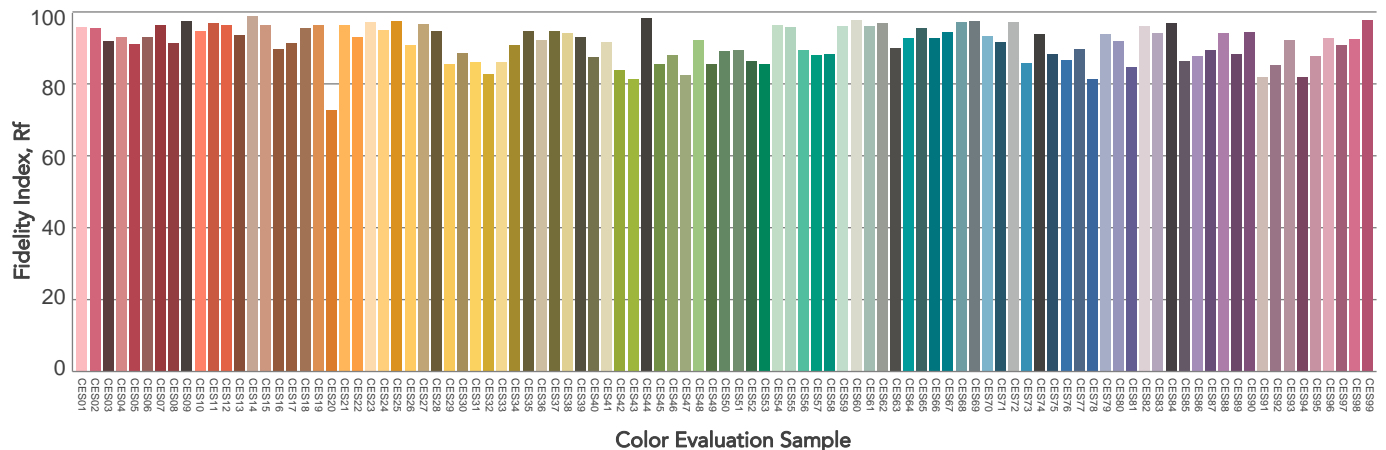
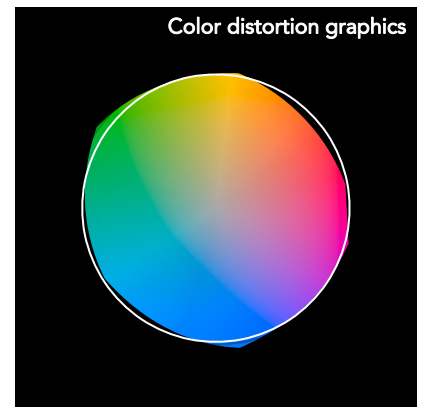
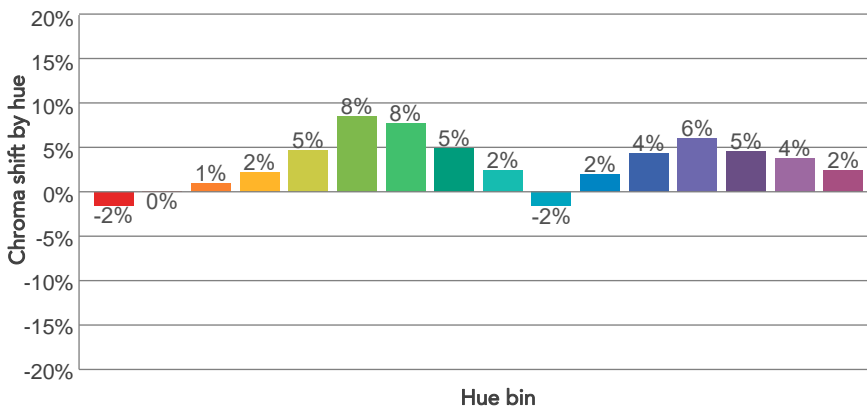
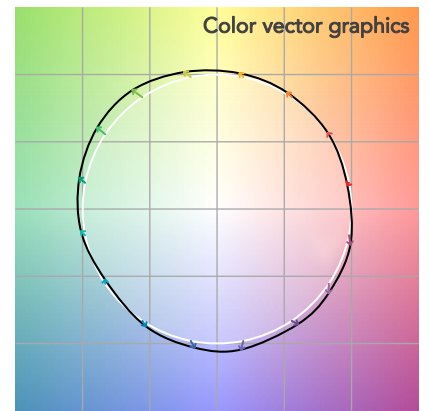
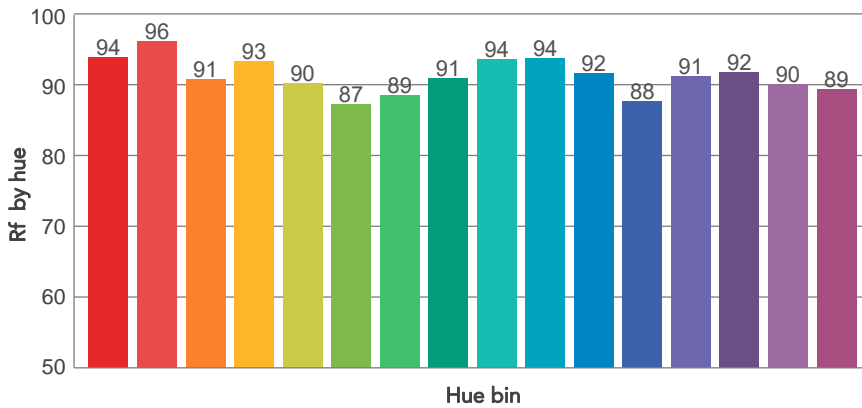
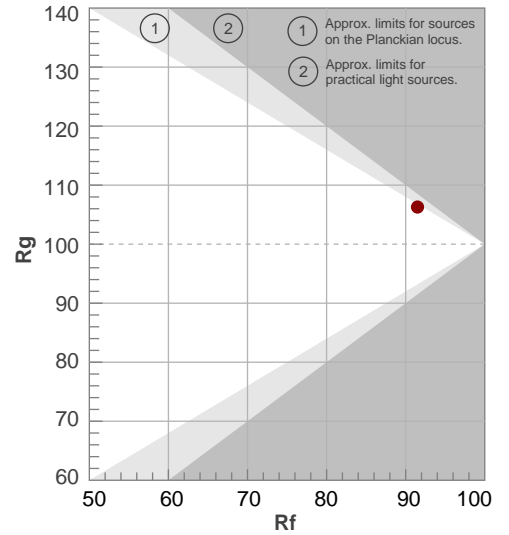

BEAM DETAILS



Beam angle 50%	Field angle 10%	Cut off angle 2,5%	Intensity ratio in 120° cone	Intensity ratio in 90° cone
47,7°	54,3°	55,6°	99,0%	98,7%

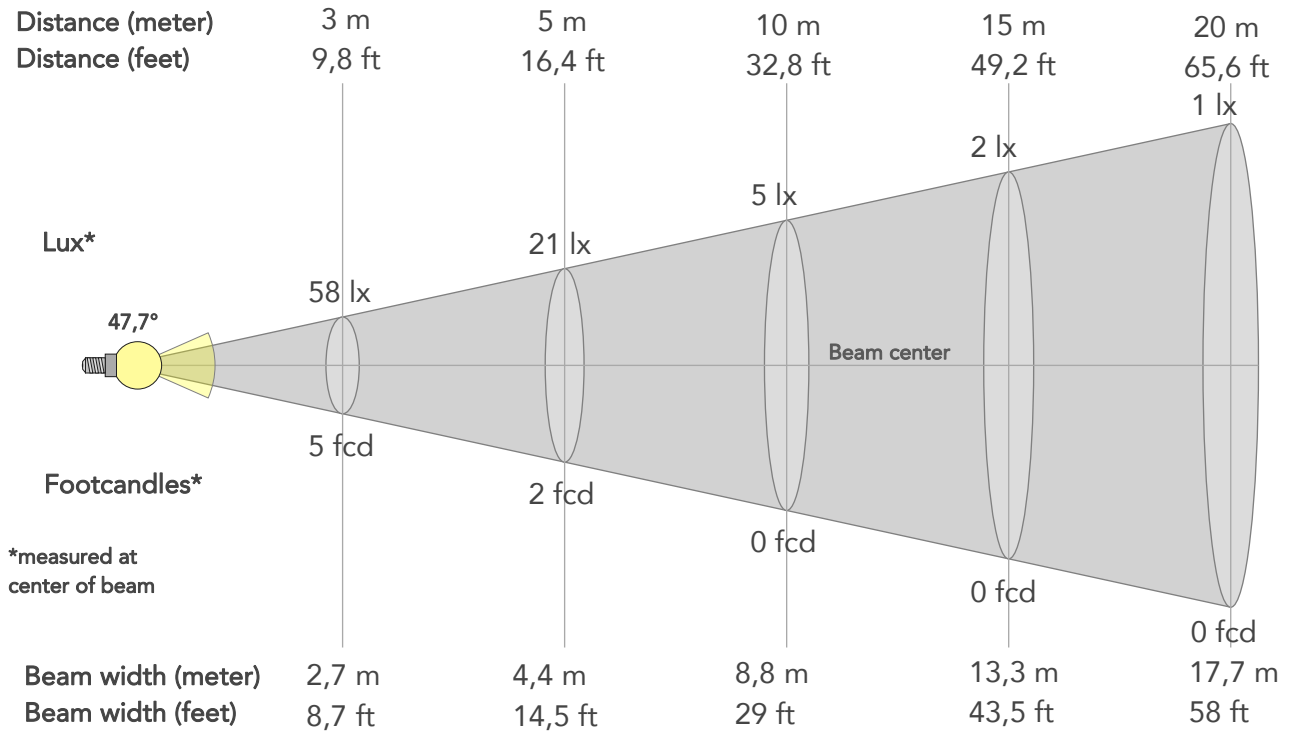

BEAM INTENSITIES AND WIDTHS

Distance	1m	2m	3m	4m	5m	7,5m	10m	15m	20m	25m	30m	40m	50m
Distance	3,3ft	6,6ft	9,8ft	13,1ft	16,4ft	24,6ft	32,8ft	49,2ft	65,6ft	82ft	98,4ft	131,2ft	164ft
Lux	519lx	130lx	58lx	32lx	21lx	9lx	5lx	2lx	1lx	1lx	1lx	0lx	0lx
Footcand.	48fcd	12fcd	5fcd	3fcd	2fcd	1fcd	0fcd	0fcd	0fcd	0fcd	0fcd	0fcd	0fcd
Beam wid.	0,9m	1,8m	2,7m	3,5m	4,4m	6,6m	8,8m	13,3m	17,7m	22,1m	26,5m	35,4m	44,2m
Beam wid.	2,9ft	5,8ft	8,7ft	11,6ft	14,5ft	21,8ft	29ft	43,5ft	58ft	72,5ft	87ft	116ft	145ft

LINEAR DISTRIBUTION DIAGRAM

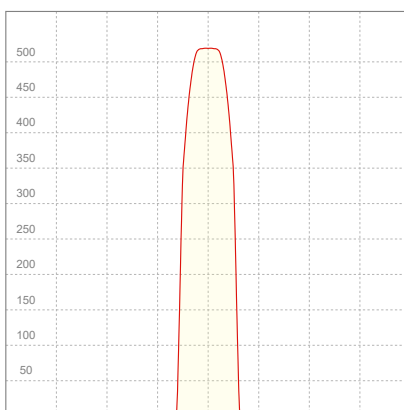

ELECTRICAL SPECIFICATIONS

Input voltage	Input current	Input power	Power FC	Efficiency
227V	0,283A	28,1W	0,44	9lm/W

ISO DIAGRAMS

ISO CANDELA DIAGRAM

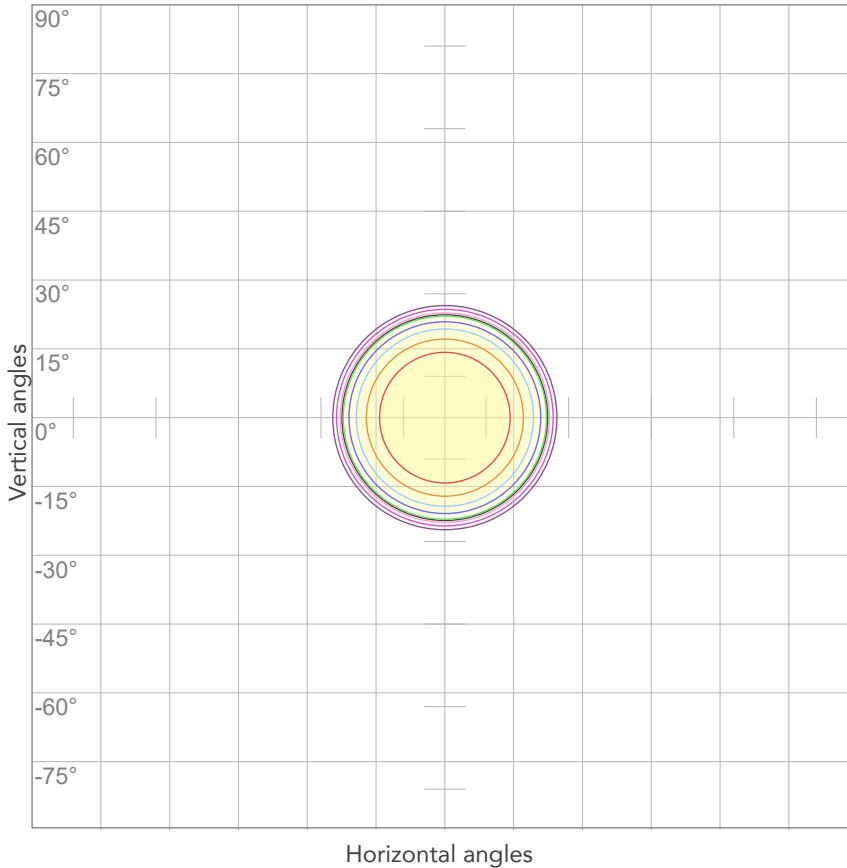

10%	52 cd
20%	104 cd
30%	156 cd
40%	208 cd
50%	260 cd
60%	311 cd
70%	363 cd
80%	415 cd

Conditions:

Number of c-planes: 2
Candela at center: 519 cd

ISO LUX DIAGRAM

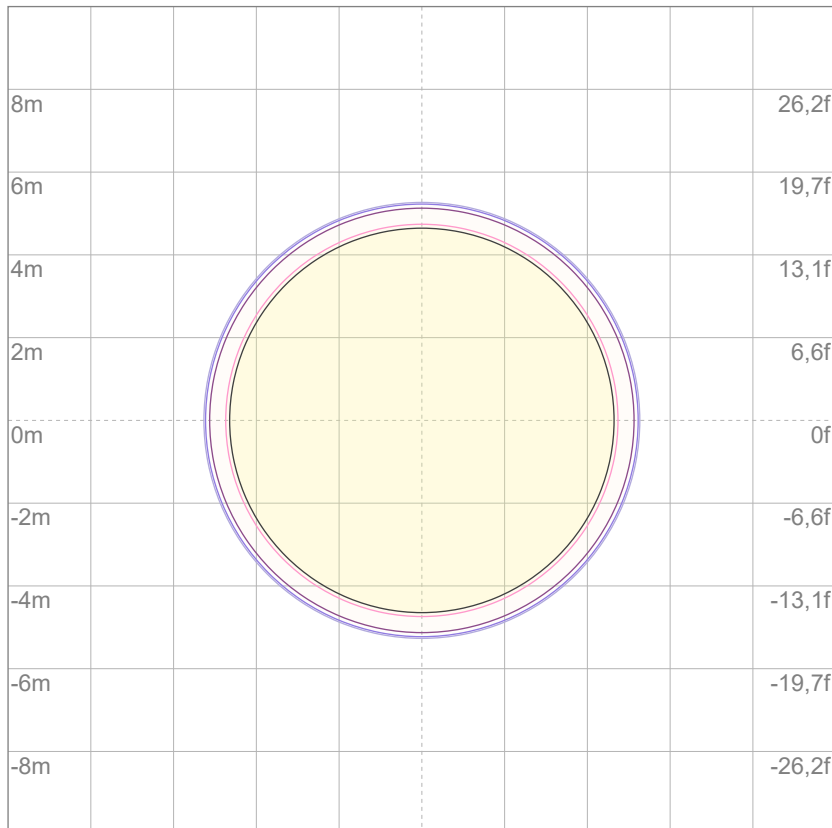

3%	0,156 lx
5%	0,260 lx
10%	0,519 lx
30%	1,56 lx
50%	2,60 lx

Conditions:

Number of c-planes: 2
Lux at center: 5,19 lx

Lux distribution on a surface when lamp is mounted at 10 meters from the surface.

Mounting height: 10 meters (33 feet)



Total lumen output:

272 lm

Peak candela output:

534 cd

Light quality:

CRI: 90,7

Color temperature:

5660 K

PRODUCT NAME:

ECLDISPLAY FC

MEASURAMENT CONDITIONS:

Beam angle:

Profile 50°

Target:

5600K

Operator:

Salvatore Giglio

Date and time:

07/02/2024 09:45:31

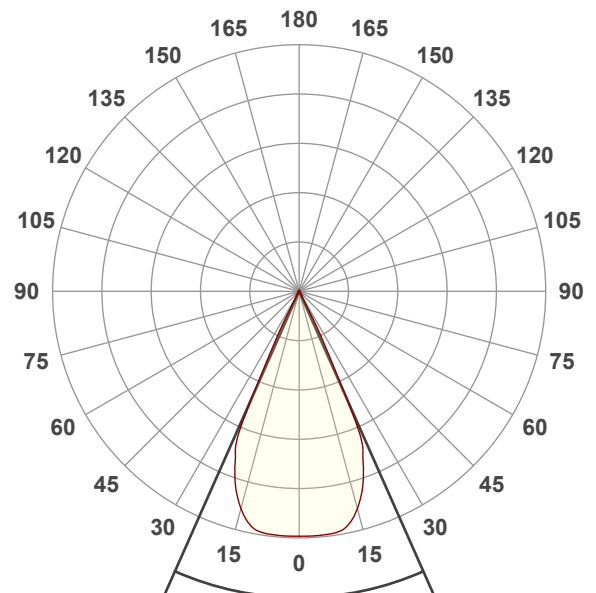

Beam angle 50%: 47,8°

Field angle 10%: 54,5°

Cut off angle 2.5%: 56,5°

Spectra

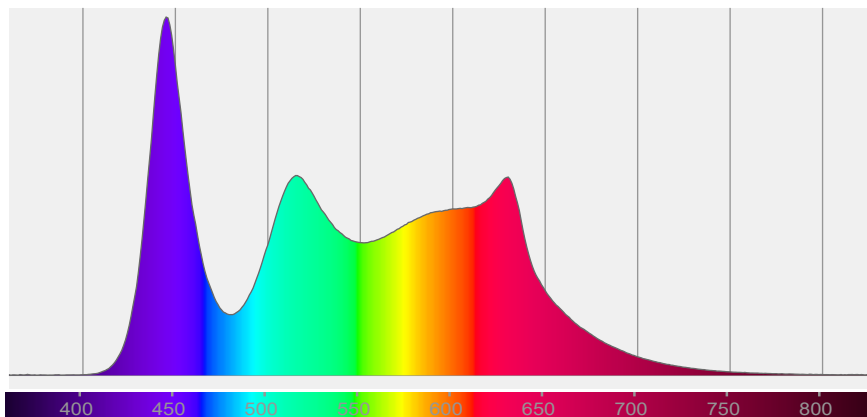

COLOR DETAILS

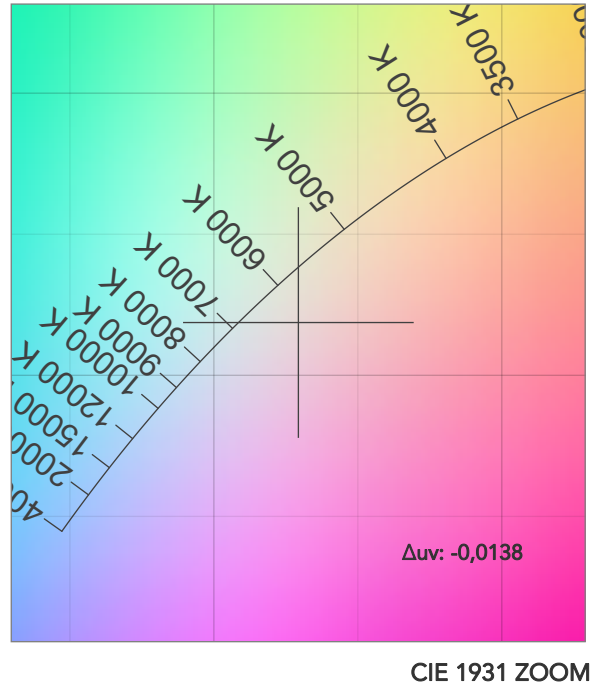
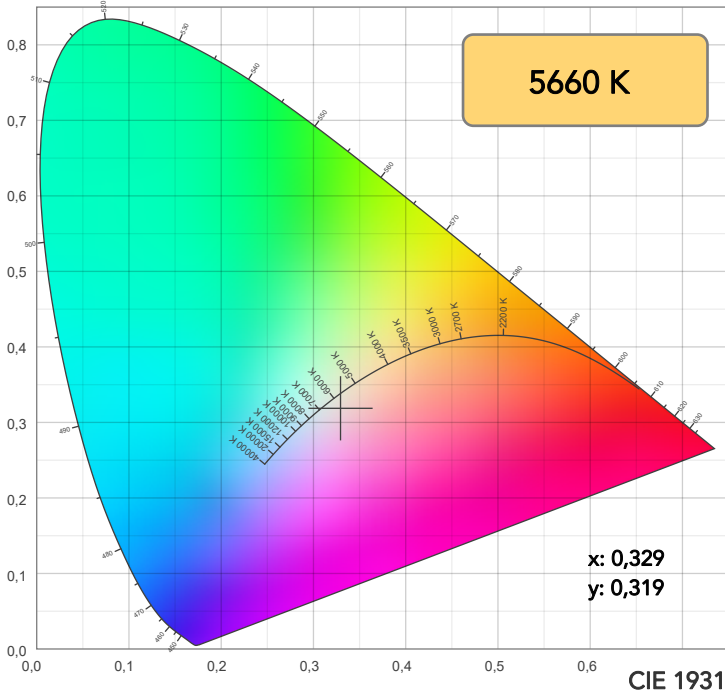

TM30: 88,2

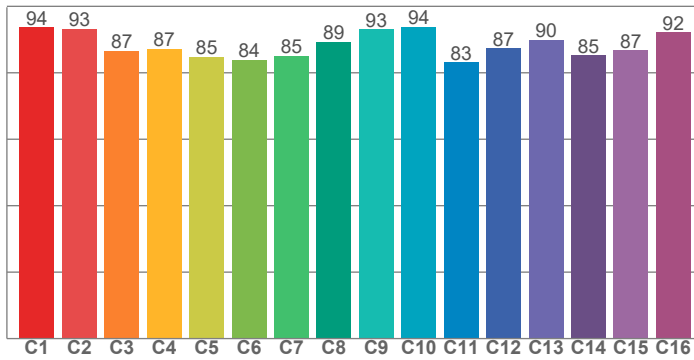

CRI: 90,7 (R1-R8)

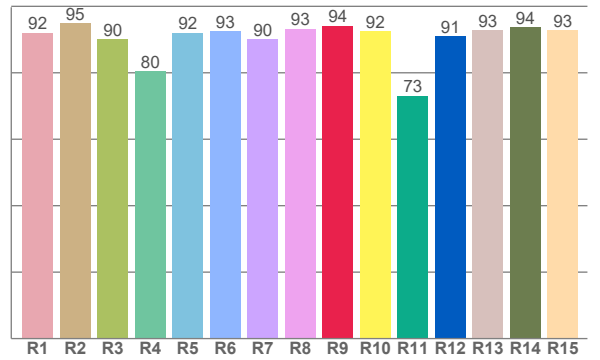

CQS: 91,2

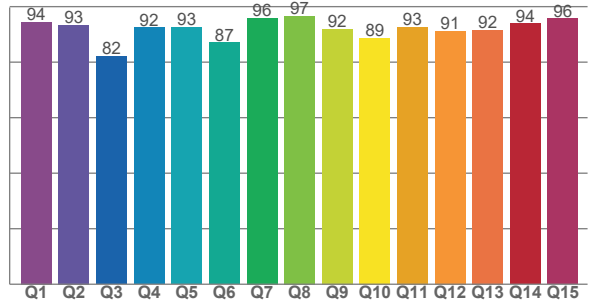

CRI R values, only R1-R8 are used to calculate final CRI value

R1	R2	R3	R4	R5	R6	R7	R8	R9	R10	R11	R12	R13	R14	R15
92,0	94,9	90,1	80,5	92,0	92,5	90,2	93,3	94,2	92,4	73,1	91,0	92,7	93,7	92,7

TM30 C values, 16 binned values out of total of 99 C values

C1	C2	C3	C4	C5	C6	C7	C8	C9	C10	C11	C12	C13	C14	C15	C16
93,6	93,2	86,7	87,3	84,8	83,8	85,1	89,3	93,1	93,9	83,1	87,3	89,8	85,2	86,8	92,2

CQS Q values

Q1	Q2	Q3	Q4	Q5	Q6	Q7	Q8	Q9	Q10	Q11	Q12	Q13	Q14	Q15
94,5	93,3	82,1	92,4	92,6	87,1	95,9	96,6	91,9	88,7	92,6	91,2	91,7	94,0	95,7

COLOR PARAMETERS

Color temperature	Color rendering index	Red component	Color fidelity	Color gamut	Color quality scale	Television lighting index	Color coordinate cie 1931	Color coordinate cie 1931	Color deviation from black body
CCT	CRI	CRI R9	TM30 Rf	TM30 Rg	CQS	TLCI	x	y	Δuv
5660 K	90,7	94,2	88,2	108,9	91,2	83	0,329	0,319	-0,0138

TM30 DETAILS

Rf 88,2
Fidelity index Rf

Rg 108,9
Gammut index

Hue Bin	R _f	Graphic shifts (%)	
		Chroma	Hue
1	94	-1%	-2%
2	93	0%	3%
3	87	1%	7%
4	87	4%	7%
5	85	7%	6%
6	84	11%	5%
7	85	10%	0%
8	89	5%	-3%
9	93	1%	-4%
10	94	-2%	1%
11	83	1%	10%
12	87	4%	8%
13	90	8%	4%
14	85	8%	5%
15	87	10%	-6%
16	92	4%	-2%

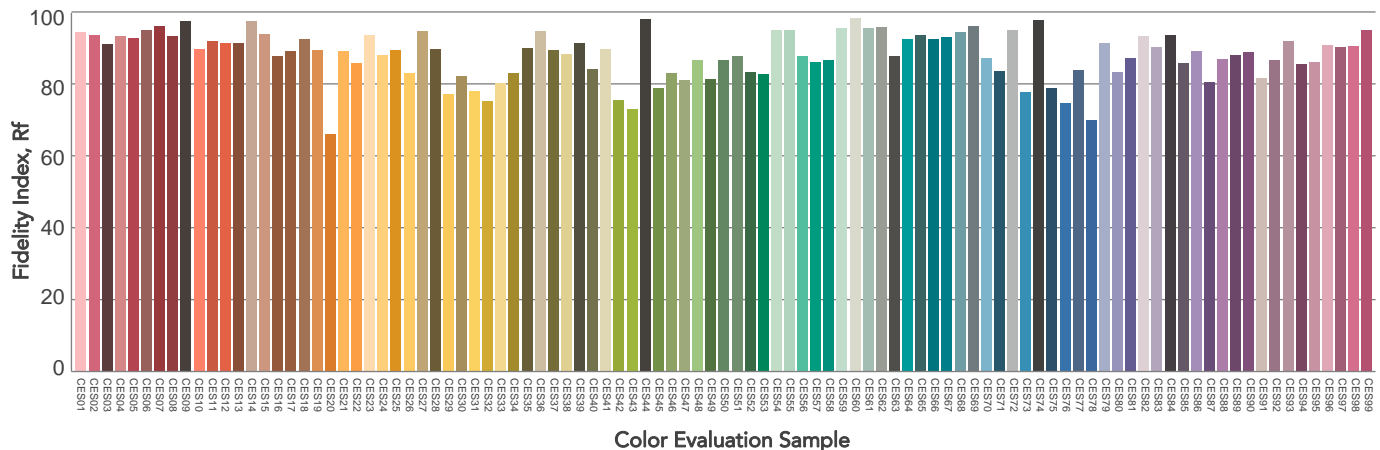
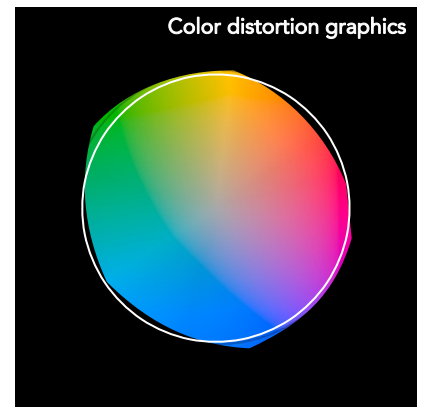
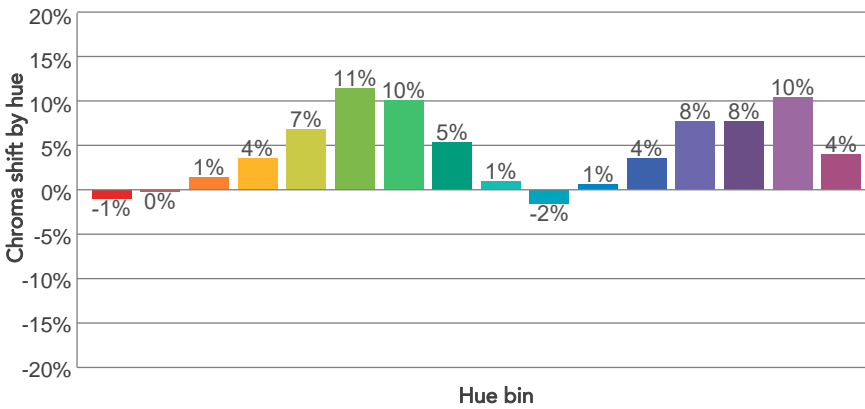
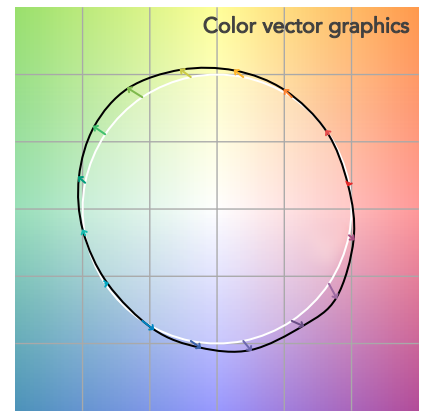
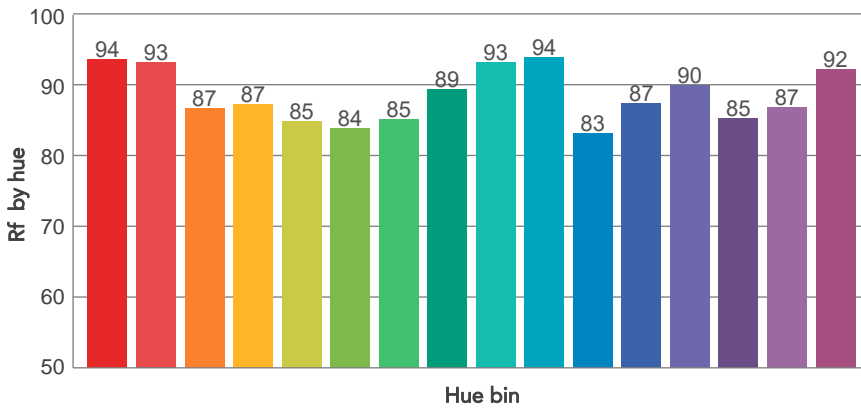
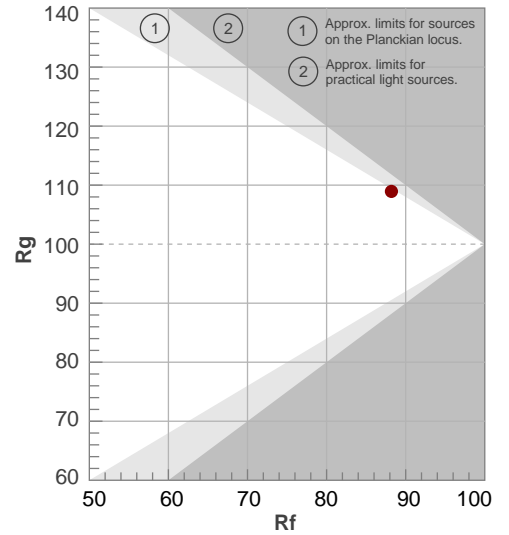

BEAM DETAILS



Beam angle 50%	Field angle 10%	Cut off angle 2,5%	Intensity ratio in 120° cone	Intensity ratio in 90° cone
47,8°	54,5°	56,5°	98,9%	98,6%

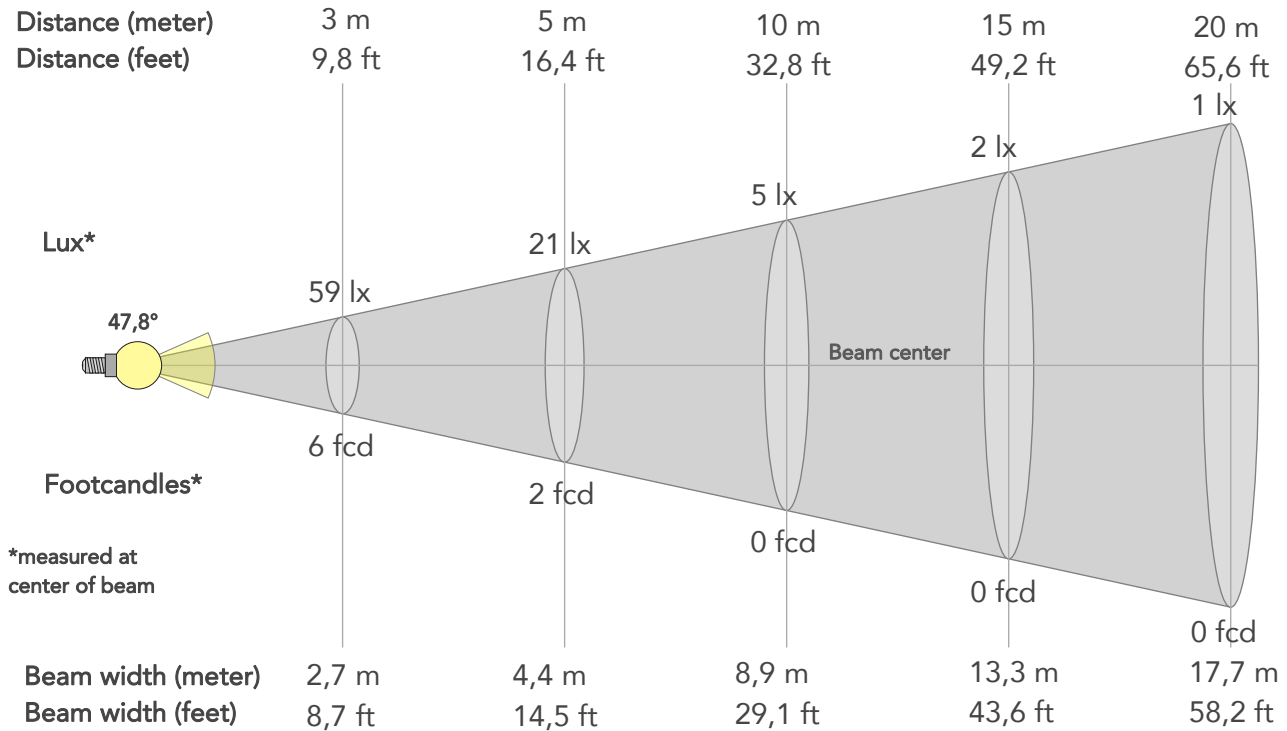

BEAM INTENSITIES AND WIDTHS

Distance	1m	2m	3m	4m	5m	7,5m	10m	15m	20m	25m	30m	40m	50m
Distance	3,3ft	6,6ft	9,8ft	13,1ft	16,4ft	24,6ft	32,8ft	49,2ft	65,6ft	82ft	98,4ft	131,2ft	164ft
Lux	534lx	134lx	59lx	33lx	21lx	9lx	5lx	2lx	1lx	1lx	1lx	0lx	0lx
Footcand.	50fcd	12fcd	6fcd	3fcd	2fcd	1fcd	0fcd	0fcd	0fcd	0fcd	0fcd	0fcd	0fcd
Beam wid.	0,9m	1,8m	2,7m	3,5m	4,4m	6,7m	8,9m	13,3m	17,7m	22,2m	26,6m	35,5m	44,4m
Beam wid.	2,9ft	5,9ft	8,7ft	11,6ft	14,5ft	21,8ft	29,1ft	43,6ft	58,2ft	72,7ft	87,3ft	116,4ft	145,5ft

LINEAR DISTRIBUTION DIAGRAM

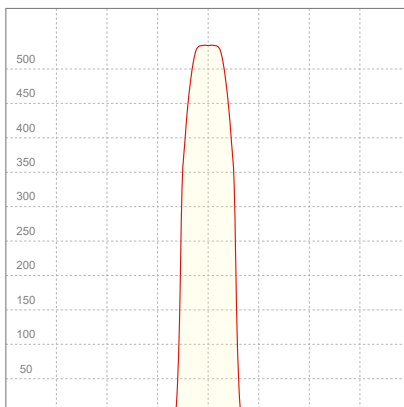

ELECTRICAL SPECIFICATIONS

Input voltage	Input current	Input power	Power FC	Efficiency
225V	0,299A	30,1W	0,45	9lm/W

ISO DIAGRAMS

ISO CANDELA DIAGRAM

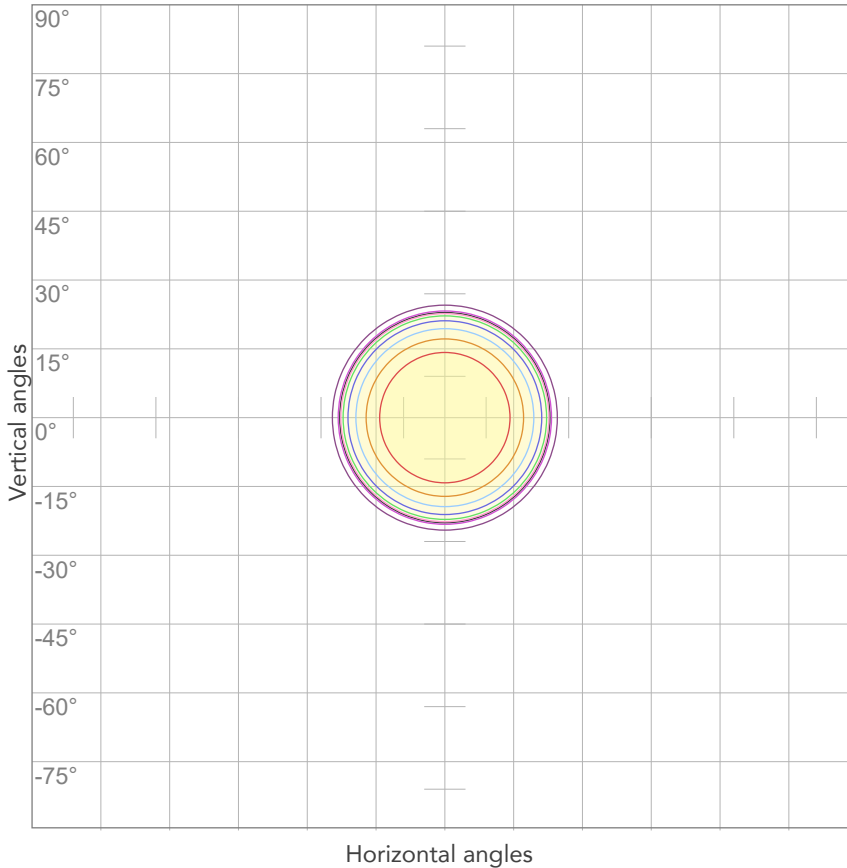

10%	53 cd
20%	107 cd
30%	160 cd
40%	214 cd
50%	267 cd
60%	321 cd
70%	374 cd
80%	427 cd

Conditions:

Number of c-planes: 2
Candela at center: 534 cd

ISO LUX DIAGRAM

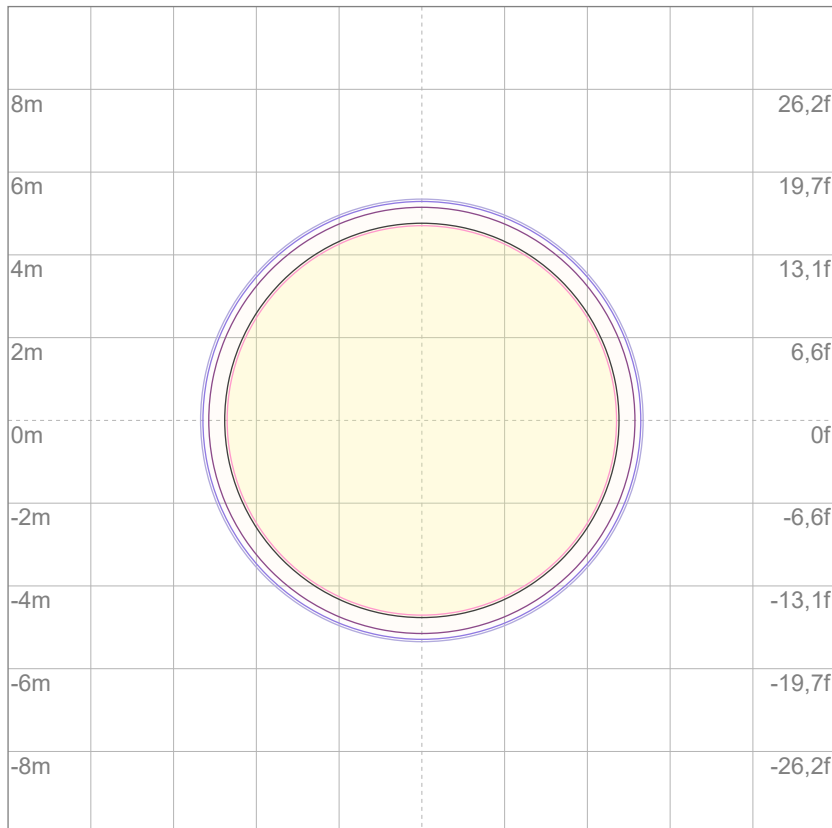

Mounting height: 10 meters (33 feet)

3%	0,160 lx
5%	0,267 lx
10%	0,534 lx
30%	1,60 lx
50%	2,67 lx

Conditions:

Number of c-planes: 2
Lux at center: 5,34 lx

Lux distribution on a surface when lamp is mounted at 10 meters from the surface.



Total lumen output:

274 lm

Peak candela output:

539 cd

Light quality:

CRI: 90,3

Color temperature:

6095 K

PRODUCT NAME:

ECLDISPLAY FC

MEASURAMENT CONDITIONS:

Beam angle:

Profile 50°

Target:

6000K

Operator:

Salvatore Giglio

Date and time:

07/02/2024 10:16:27

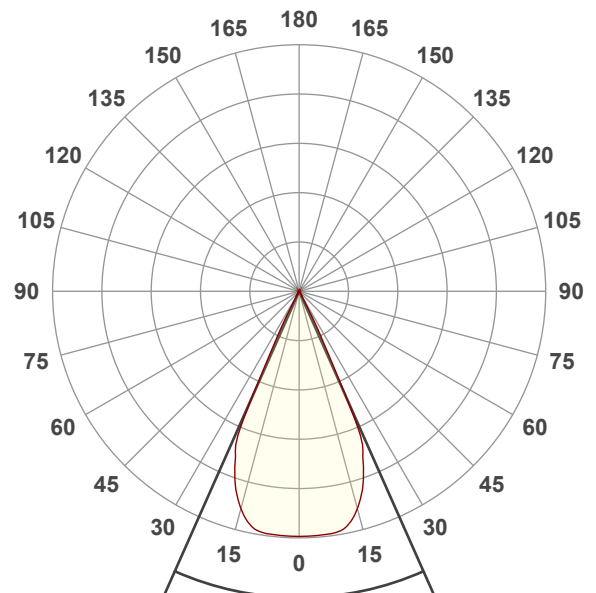

Beam angle 50%: 47,9°

Field angle 10%: 54,5°

Cut off angle 2.5%: 56,6°

Spectra

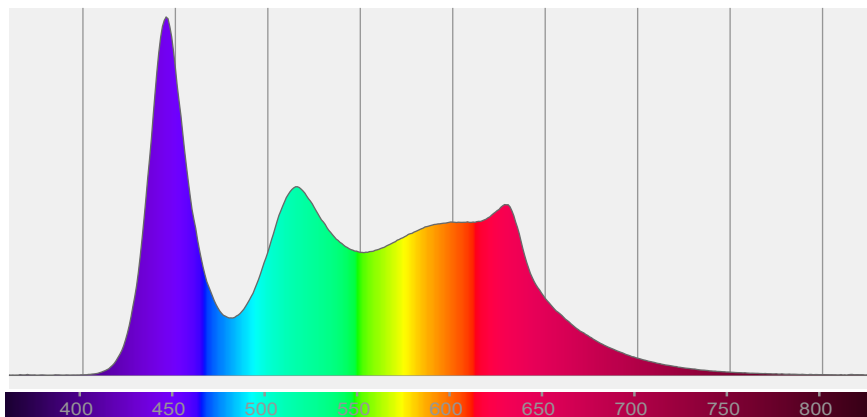

COLOR DETAILS

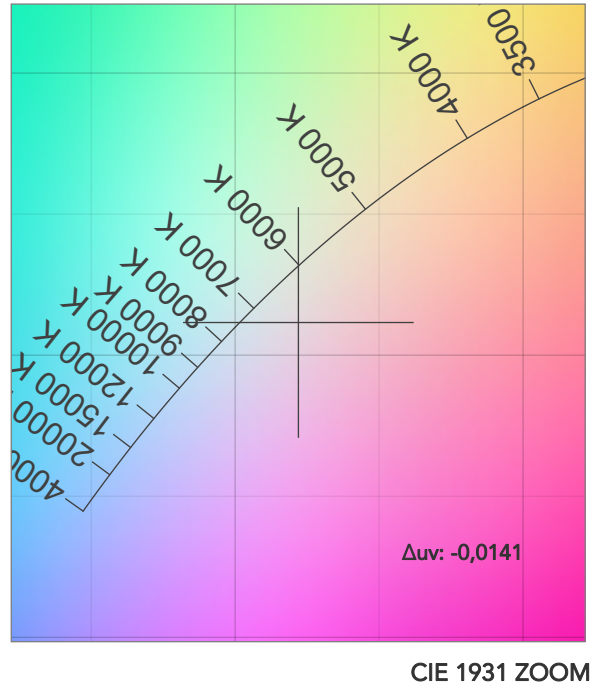
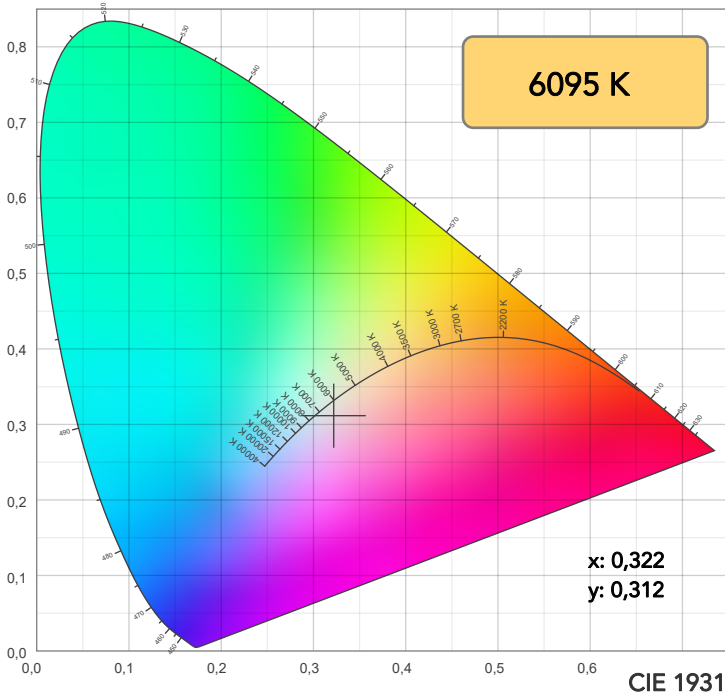

TM30: 87,7

CRI: 90,3 (R1-R8)

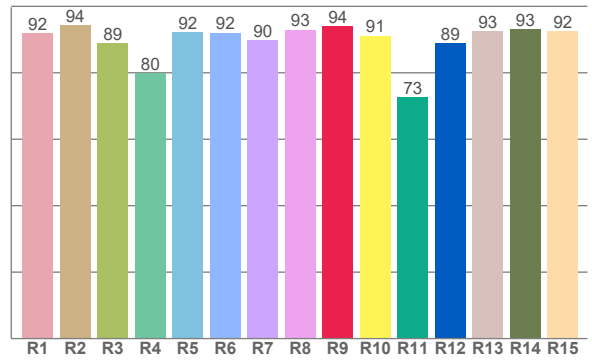
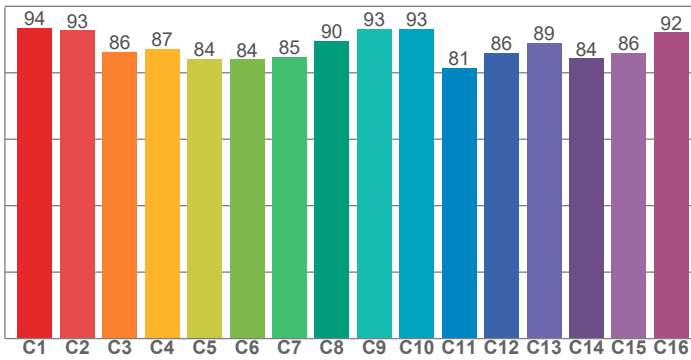

CRI R values, only R1-R8 are used to calculate final CRI value

R1	R2	R3	R4	R5	R6	R7	R8	R9	R10	R11	R12	R13	R14	R15
91,9	94,4	88,9	79,9	92,3	92,0	89,7	93,0	93,9	91,2	72,5	88,8	92,5	93,0	92,5

TM30 C values, 16 binned values out of total of 99 C values

C1	C2	C3	C4	C5	C6	C7	C8	C9	C10	C11	C12	C13	C14	C15	C16
93,6	92,8	86,2	87,3	84,2	84,0	84,8	89,7	93,2	93,3	81,5	86,0	89,0	84,3	86,0	92,1

CQS Q values

Q1	Q2	Q3	Q4	Q5	Q6	Q7	Q8	Q9	Q10	Q11	Q12	Q13	Q14	Q15
94,9	92,8	81,1	91,0	93,3	87,8	96,6	96,0	91,1	87,9	91,7	90,4	91,0	93,6	95,7

CQS: 90,8

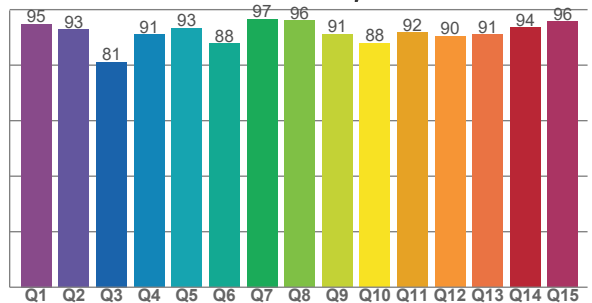

COLOR PARAMETERS

Color temperature	Color rendering index	Red component	Color fidelity	Color gamut	Color quality scale	Television lighting index	Color coordinate cie 1931	Color coordinate cie 1931	Color deviation from black body
CCT	CRI	CRI R9	TM30 Rf	TM30 Rg	CQS	TLCI	x	y	Δuv
6095 K	90,3	93,9	87,7	109,0	90,8	83	0,322	0,312	-0,0141

TM30 DETAILS

Rf 87,7
Fidelity index Rf

Rg 109,0
Gammut index

Hue Bin	R _f	Graphic shifts (%)	
		Chroma	Hue
1	94	-1%	-2%
2	93	0%	3%
3	86	1%	8%
4	87	3%	7%
5	84	7%	6%
6	84	11%	5%
7	85	10%	1%
8	90	5%	-3%
9	93	1%	-3%
10	93	-2%	2%
11	81	1%	11%
12	86	3%	9%
13	89	8%	5%
14	84	8%	6%
15	86	12%	-5%
16	92	4%	-2%

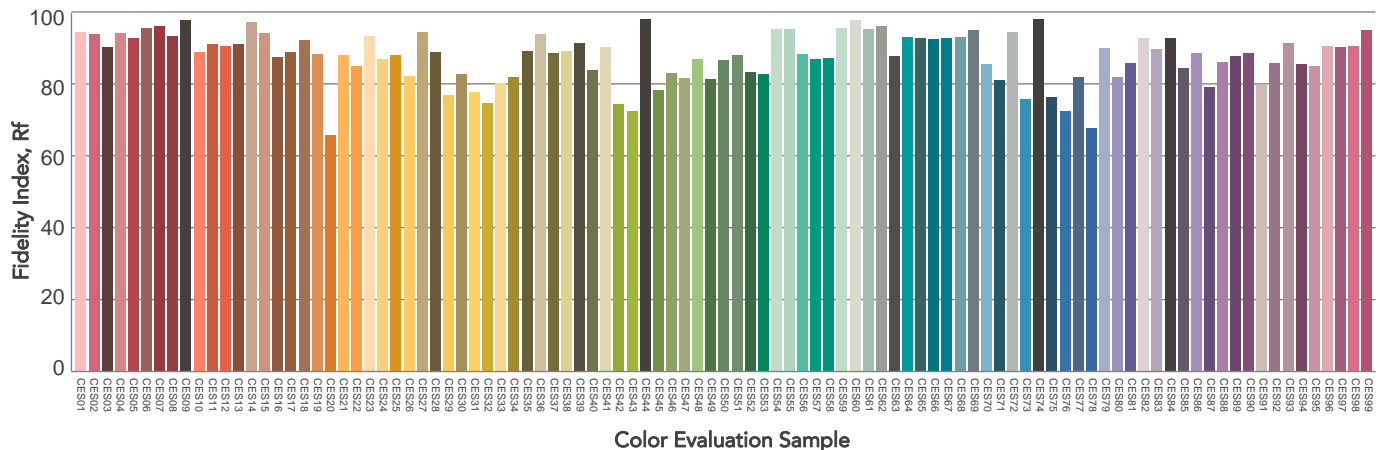
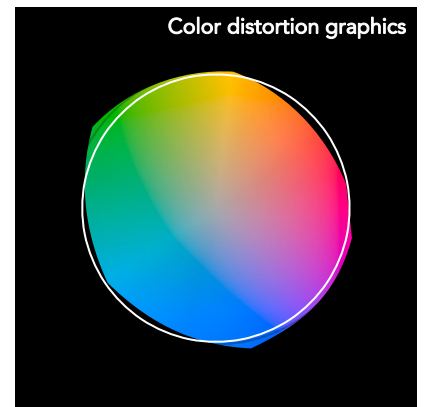
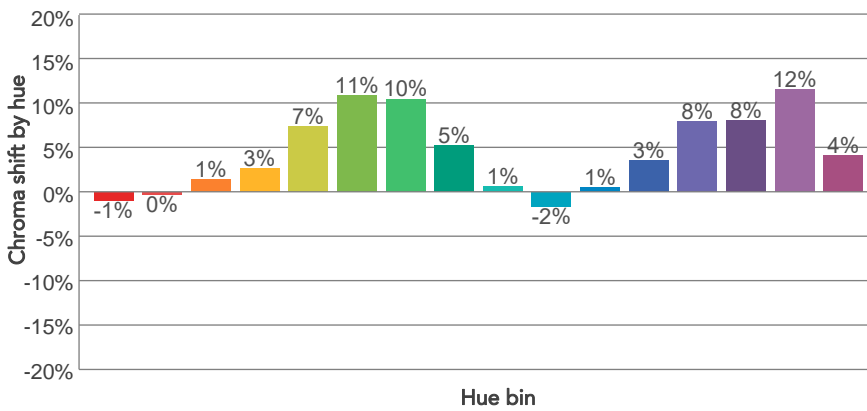
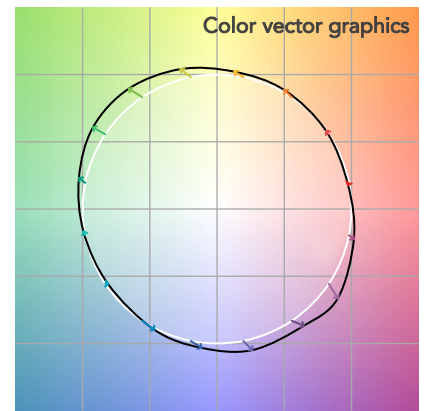
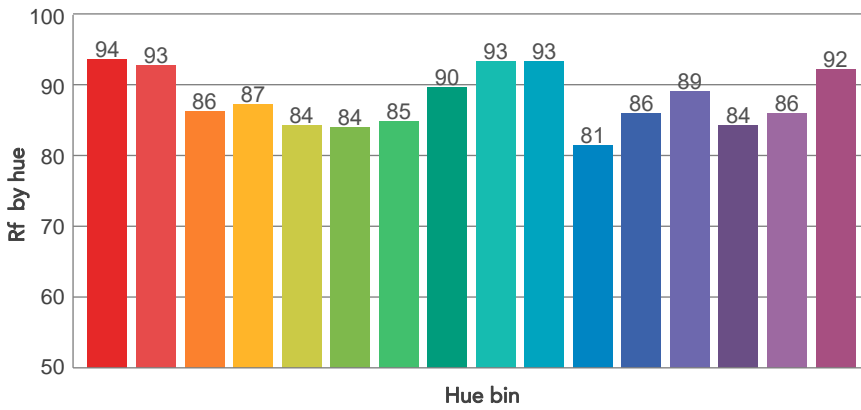
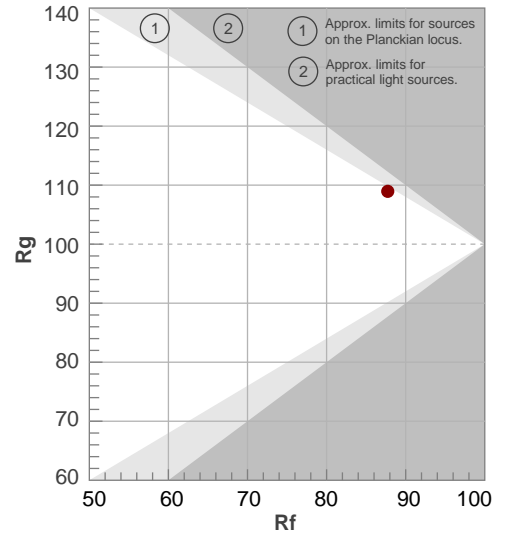

BEAM DETAILS



Beam angle 50%	Field angle 10%	Cut off angle 2,5%	Intensity ratio in 120° cone	Intensity ratio in 90° cone
47,9°	54,5°	56,6°	99,1%	98,8%

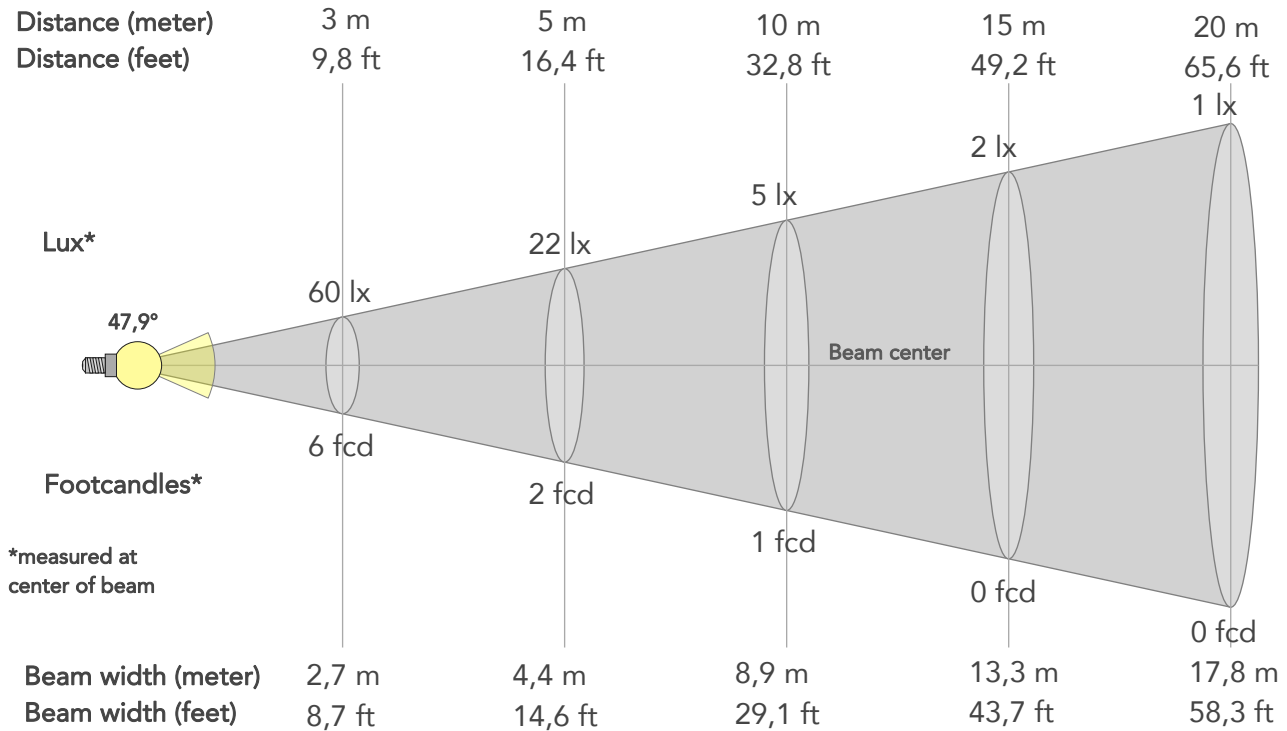

BEAM INTENSITIES AND WIDTHS

Distance	1m	2m	3m	4m	5m	7,5m	10m	15m	20m	25m	30m	40m	50m
Distance	3,3ft	6,6ft	9,8ft	13,1ft	16,4ft	24,6ft	32,8ft	49,2ft	65,6ft	82ft	98,4ft	131,2ft	164ft
Lux	539lx	135lx	60lx	34lx	22lx	10lx	5lx	2lx	1lx	1lx	1lx	0lx	0lx
Footcand.	50fcd	13fcd	6fcd	3fcd	2fcd	1fcd	1fcd	0fcd	0fcd	0fcd	0fcd	0fcd	0fcd
Beam wid.	0,9m	1,8m	2,7m	3,6m	4,4m	6,7m	8,9m	13,3m	17,8m	22,2m	26,6m	35,5m	44,4m
Beam wid.	2,9ft	5,9ft	8,7ft	11,6ft	14,6ft	21,9ft	29,1ft	43,7ft	58,3ft	72,8ft	87,4ft	116,5ft	145,7ft

LINEAR DISTRIBUTION DIAGRAM

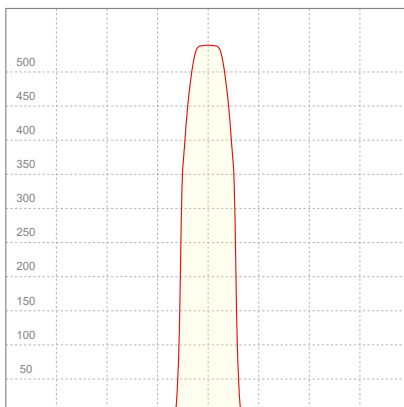

ELECTRICAL SPECIFICATIONS

Input voltage	Input current	Input power	Power FC	Efficiency
224V	0,296A	30,2W	0,46	9lm/W

ISO DIAGRAMS

ISO CANDELA DIAGRAM

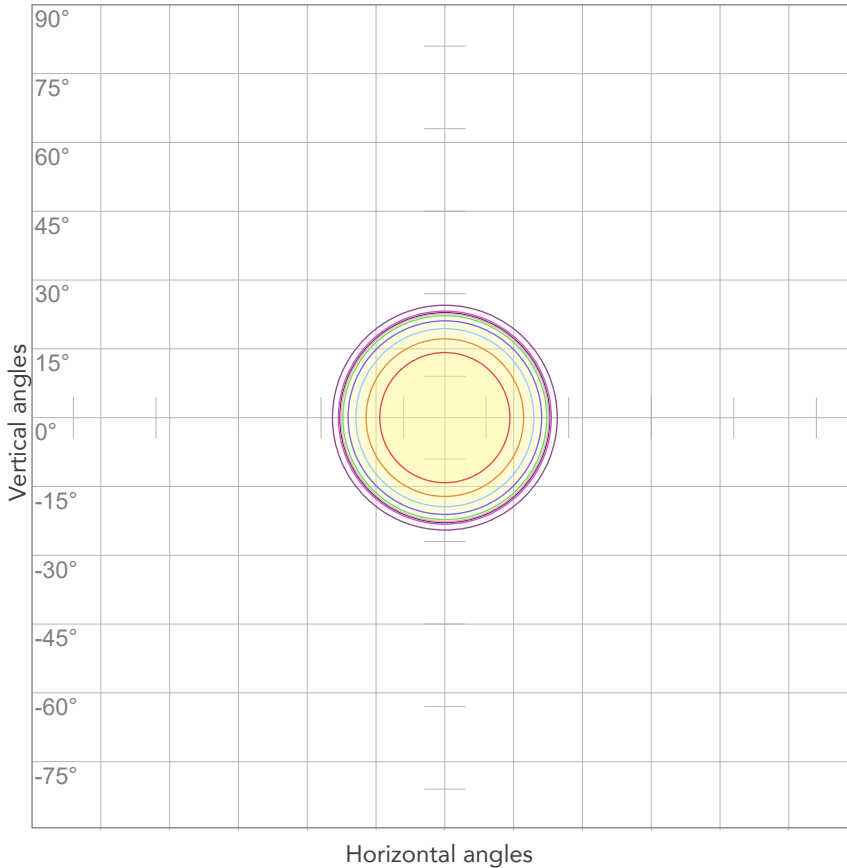

10%	54 cd
20%	108 cd
30%	162 cd
40%	216 cd
50%	270 cd
60%	323 cd
70%	377 cd
80%	431 cd

Conditions:

Number of c-planes: 2
Candela at center: 539 cd

ISO LUX DIAGRAM

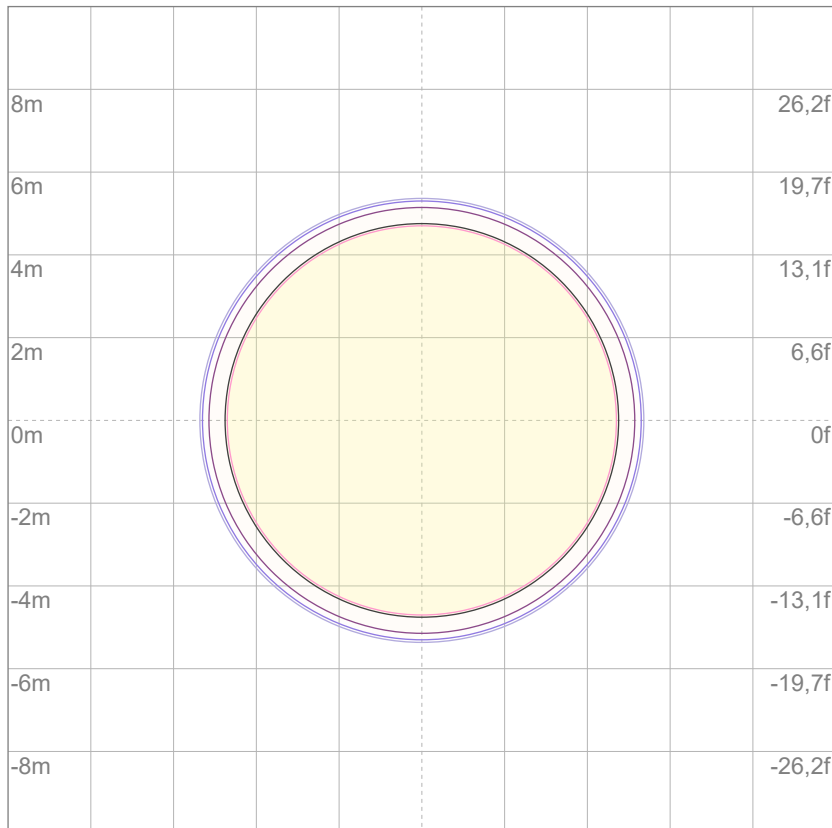

3%	0,162 lx
5%	0,270 lx
10%	0,539 lx
30%	1,62 lx
50%	2,70 lx

Conditions:

Number of c-planes: 2
Lux at center: 5,39 lx

Lux distribution on a surface when lamp is mounted at 10 meters from the surface.

Mounting height: 10 meters (33 feet)